

NanoCourses 2004, Section 3

Practical Thin Film Technology

The Flatland of Thin Films
Puttin' 'em on and Takin' 'em off

Process Integration
by
Michael Skvarla

Presented by the
CNF Technical Staff
for the education of CNF Users,
Potential Users, and Industrial Sponsors



CNF NanoCourses



Thin Film Technology, page 1



Process Integration

- A consideration of the sum of ALL processing steps to arrive at the proper parameters for each in order to make a functional (and reliable) device/circuit/system
 - Thermal budgets (stress, diffusion, ...), thermal history
 - Materials interactions and compatibility
 - Selectivity, chemical sensitivity, etch rates
 - Process latitude (reproducibility)
 - Registration (level-to-level)
 - “mystery phenomena” (hand waving and buzz words)
- Steps in a fabrication process are INTERRELATED and can often involve severe conditions
- The final result is due to the **combined** effects of ALL of the individual steps



CNF NanoCourses



Thin Film Technology, page 2



Process Integration

- Fabrication is the orderly processing of layers of functionality (doping, contacts, insulation, patterns,) in the optimum sequence to produce a “system, circuit, device.”
- Commercial electronic chip: 30+ masks
- Research:
 - 1-3 layers for the simplest (micro-fluidics)
 - Up to 50 for some complex devices (3D integration)



CNF NanoCourses



Thin Film Technology, page 3



Process Integration - BiCMOS

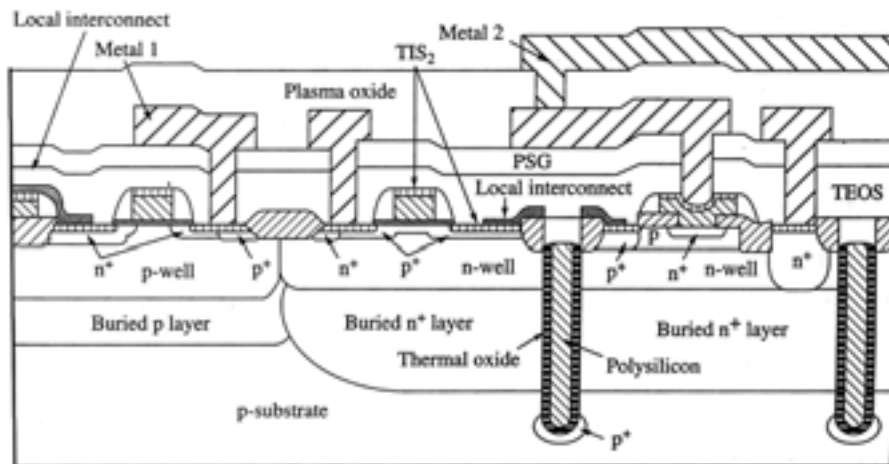

CNF NanoCourses



Thin Film Technology, page 4



Process Integration - - an example

- A prominent example is the attempt to use a metal for an ion implantation mask (Ions change the electrical properties)
- If the film deposits as columnar grains (NOT continuous film), the ions can pass between the grains and modify the sample

Process Integration - - an example

- A prominent example is the attempt to use a metal for an ion implantation mask (Ions change the electrical properties)
- If the film deposits as columnar grains (NOT continuous film), the ions can pass between the grains and modify the sample

- Expect this



for

- but get this

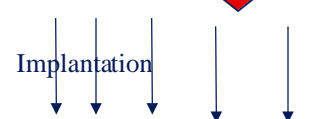

Process Integration - Approach

- Understand the process
- Characterize the process (individual steps)
 - ***** this can involve extensive experimentation
- Consider the sequence of the steps
- Consider the effects of subsequent processing operations when deciding the parameters for the present step
- Consider engineering tradeoffs for the optimum result
- Be willing to Compromise
- Be willing to modify the process flow (or even redesign it !!)
- Be Creative !



CNF NanoCourses



Thin Film Technology, page 7



NanoCourses 2004, Section 3

Practical Thin Film Technology

The Flatland of Thin Films
Puttin' 'em on and Takin' 'em off

Properties of Thin Films
by
Michael Skvarla

Presented by the
CNF Technical Staff
for the education of CNF Users,
Potential Users, and Industrial Sponsors



CNF NanoCourses



Thin Film Technology, page 8



Thin Films: Outline

- Introduction
- Terms and Definitions
- Film Attributes
- Growth Mechanism and Kinetics
- Growth Techniques
- A Few Examples



1. Introduction

Things to Think About



Why Thin Films?

Thin films play a role in virtually every micro- and nanostructure!

- **Conductors : (Metals, metal compounds)**
 - Connecting things (transistors) much harder (\$) than making them
 - Typically used for contacts, interconnects, structures
 - Semiconductor devices, MEMS devices, piezoelectric devices
- **Insulators: (Electrical isolation, . . .)**
 - Dielectrics for MOS structures, capacitors (SiO_x , etc.)
 - Mask applications
- **Semiconductors: (transistors, diodes, resistors, capacitors)**
 - Epitaxial layers (MBE, OMCVD)
 - Amorphous and polycrystalline layers
 - Solar cells, thin film transistors, electrical contacts



CNF NanoCourses



Thin Film Technology, page 11



“Thin” ??

- Atomic separation in a solid = 0.3 nanometer (10^{-9} m) (few Å)
- -----
- **THIN FILMS -- nanometers (monolayers) to microns**
 - High Surface/Volume ratio
 - Thin film properties (different from the bulk)
- -----
- **Hundreds of atomic layers = micrometers (10^{-6} m)**
 - Approaching “bulk” properties



CNF NanoCourses



Thin Film Technology, page 12



“Underlayer” ?? Possible Substrates

- **Silicon Wafer -- Most Common -- an incredible material !!**
 - “Pure” silicon -- contamination levels in the ppb, ppm range
 - “Perfect” crystal lattice (No defects, irregularities, ...)
 - “Flat” to within micrometers, or nanometers
 - Grown in long cylinders and sliced (like cheese) Czochralski
- **Other Semiconductors (III-IV, II-VI, etc.)**
 - Gallium Arsenide, Indium Phosphide, GaAlAs, GaAlAsP,
- **Others (many): Metals, glass, epoxy, ceramics,**
 - Crystalline or Amorphous



CNF NanoCourses



Thin Film Technology, page 13



Growth versus Deposition

- **Growth**
 - Surrounding Atoms + Surface Atoms \implies FILM
 - Consumes the substrate
 - Oxygen + Silicon Wafer produces Silicon Oxide
- **Deposition**
 - Surrounding atoms form a product . . . either :
 - 1 in the ambient and deposited onto the surface, or
 - 2 formed directly on the surface (can be “selective” dep)
- **Most films grow with their characteristic configuration**
- **Epitaxy : Film crystal structure “ordered upon” the substrate**



CNF NanoCourses



Thin Film Technology, page 14



Thin Film (Material) Functions

- Imaging
- Masking
- Structural
- Optical
- Electrical
- Biological
- Chemical
- Magnetic



CNF NanoCourses



Thin Film Technology, page 15



Integrated Process Flow

- CAD design
- Lithography (photo ----> ebeam)
- Pattern Transfer
 - Addition (deposition, growth, etc) <-----
 - Subtraction (etching, etc)
 - Modification (ion implantation)
- Analysis
- Go back to CAD - - (Next level of .. 1 .. 3 . .6 ... 30)



CNF NanoCourses



Thin Film Technology, page 16



2. Attributes

Attributes

- **Crystal Structure (Atomic planes)**
 - Intermixing encouraged (Silicides, . . .)
 - Mixing Discouraged (Diffusion barriers, . . .)
- **Grain size**
- **Composition, defects, inclusions**
- **Mechanical, optical, electrical, chemical properties**
- **Adhesion**
- **Stress**

Thin Film Thickness!

- Once a thin film is above a critical thickness, it behaves essentially as a bulk material
- Depending on the property, however, this critical thickness ranges from 100 Angstroms (e.g. electronic bandstructure) to several microns (e.g. internal stress)

Thin Film Attributes

- Thermodynamics:
 - Free energy, phase diagrams
 - Phase transformations
- Diffusion and Atomic Motion:
 - Kinetics of phase transformations
 - High diffusivity paths

Design Considerations

Microstructure: Materials are made up of atoms. Many structures may be possible, but you don't always get the one you want! Variables include crystal structure, grain structure, defects, precipitates, voids, compositional variations.

Electrical: Microstructure variations can significantly affect resistivity, mobility, dielectric function.

Atomic Mobility: Diffusivity may be very different from the bulk due to the presence of grain boundaries, voids, etc.

Mechanical: Thin films more likely to be stressed than not. Affects adhesion, general mechanical properties.

Phase Formation: ΔG , ΔH , ΔS , kT may cause formation of unusual phases.



CNF NanoCourses



Thin Film Technology, page 21



Adhesion

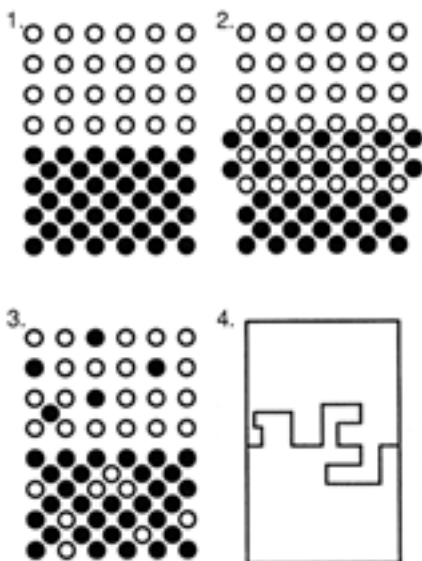

- Different interfacial layers formed between film and substrate:

- (1) Abrupt interface
- (2) Compound interface
- (3) Diffusion interface
- (4) Mechanical anchoring at interface



CNF NanoCourses



Thin Film Technology, page 22



Al-Ni Films

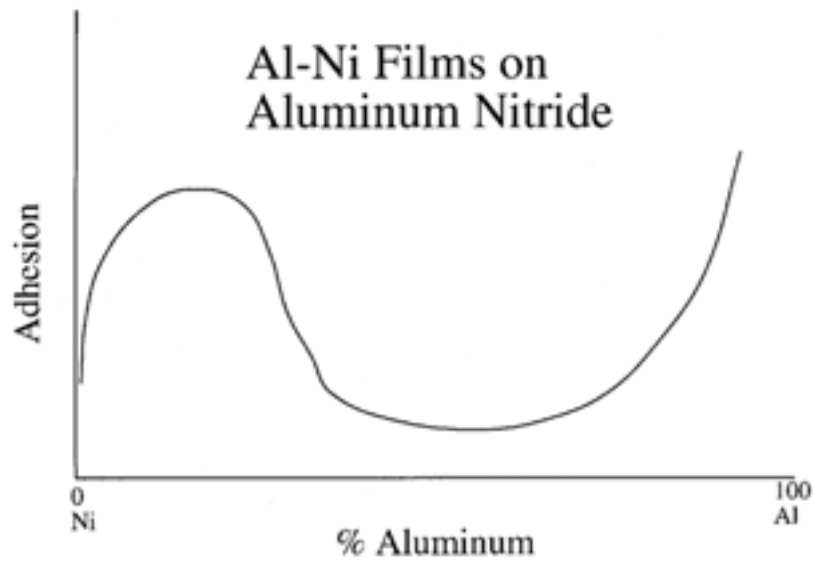

NNIN

CNF NanoCourses



Thin Film Technology, page 23

CORNELL

Stress

- Stress results from forcing atoms to take positions other than their equilibrium positions
- Atomic bonds are broken (or just bent), resulting in intrinsic stress
- Thermal stresses result from unequal expansion/contraction as the temperature changes
- Sample BOW

NNIN

CNF NanoCourses



Thin Film Technology, page 24

CORNELL

Stress

- **INTRINSIC** - - Bonds broken or bent
 - Lattice mismatch, contamination
 - Grain growth & phase transformations \implies Volume changes
- **THERMAL** - - Different coefficients of thermal expansion . . .
 - Temperature changes lead to volume changes \implies Stress

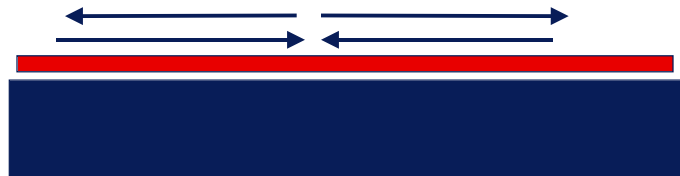

Stress

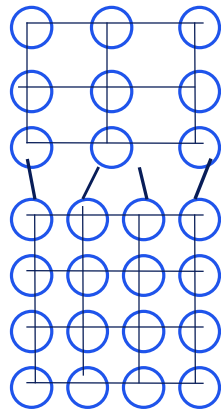

Tension
Or
Compression

Results in Wafer BOW

Crystal Structure

- Single Crystal - - - Long range order (many μm)
- Every atom finds its place (Atomic planes / Terraces)

- Poly-Crystalline - - - Medium range order (10-100 nm)
- Grains can be LARGE

- Amorphous - - - Short range order (a few nm) - -
- NO long range order

3. Growth Mechanism and Kinetics

Vapor-Phase Deposition (Vacuum) <-----

Film Production (Vapor phase)

- Source vaporized & transported to the surface
- Particles stick and coalesce into islands
- Islands coalesce into continuous covering
 - Uniform or granulated
- Continuing the process ==> Bulk Materials

Growth Kinetics

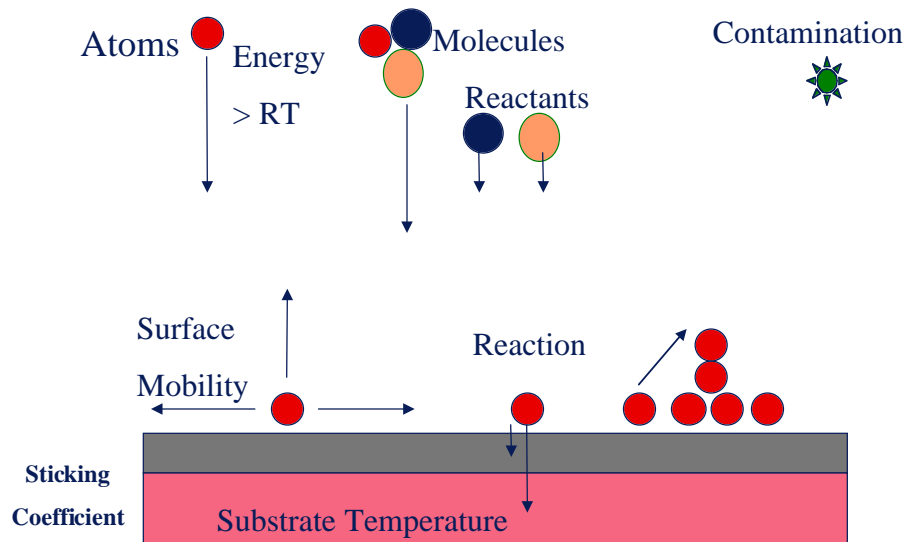

Thin Film Morphology

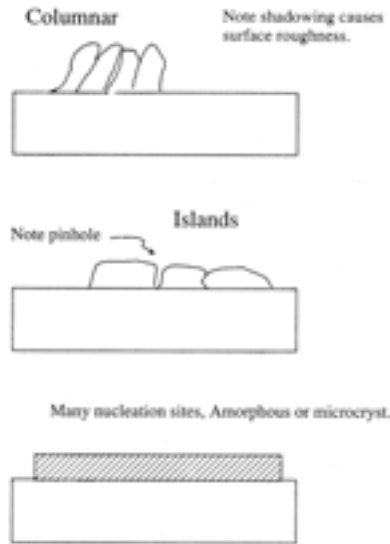

Thermodynamics, Kinetics, Nucleation

- Substrate temperature or ion bombardment can dramatically alter the microstructure of the deposited layer
 - Thermodynamics, kinetics, nucleation
- All are involved in what happens, but they also give you a wide range of possibilities

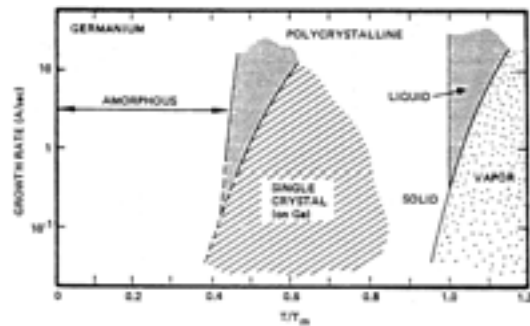

Phase and crystallographic-order transitions in germanium

Structure and Microhardness of TiC

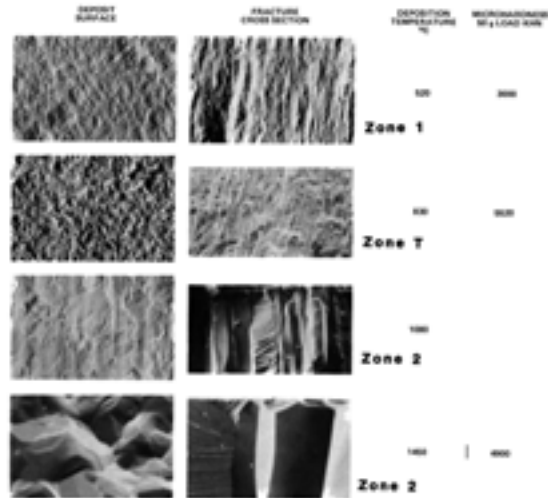

Structure and microhardness of TiC deposits at various temps (1000x), from Bunshah and Desphandey, Physics of Thin Films, vol. 13, Academic Press, San Diego, CA, 1987.



CNF NanoCourses



Thin Film Technology, page 33



Structural Zones in Condensates

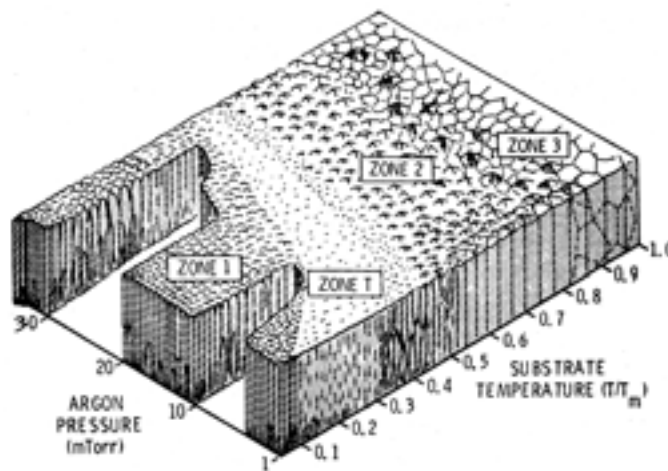

Structural zones in condensates. [After Thornton (84).]

From Bunshah and Desphandey, Physics of Thin Films, vol. 13, Academic Press, San Diego, CA, 1987.



CNF NanoCourses



Thin Film Technology, page 34



Grain Boundaries

- Film properties are **STRONGLY** influenced by the characteristics of the grain boundaries
- Diffusion along GB
- Failure Mechanisms (crack initiation, etc)
- Fatigue and Wear

Micro-Structure



Grain



Bamboo Structure

Drain Boundary Diffusion



Diffusion Distance

- At small dimensions, diffusion along high diffusivity paths, such as grain boundaries, can be significant
- Diffusion distance $\approx \sqrt{D_b t}$
- ...where D_b is the grain boundary diffusion coefficient
- Consider Al at 400°C, ($T/T_m = 0.6$), $D_b = 10^{-10} \text{ cm}^2/\text{s}$
 $\sqrt{D_b t}$ m, \gg submicron dimensions !!!
- Note -- Bulk diffusion of a few nanometers typical

Surface Energy

- The energy cost to create a surface
 - Binding energy
 - Interatomic potential energy
- Natural systems tend to minimize total energy
 - Volume energy decreases as a crystal (grain) grows
 - Surface energy increases as a crystal (grain) grows
- Liquids ball up to reduce surface energy
- Crystals facet to expose low energy surfaces



CNF NanoCourses



Thin Film Technology, page 39



Bonding

- van der Waals - dipole interaction
 - Weak \rightarrow 0.1 eV / atom pair
 - Bonding between planes. e.g. graphitic carbon, mica
- Metallic - electrons delocalize (nondirectionally)
 - Strong \rightarrow 1-10 eV / atom pair
 - Leads to ductility, high electrical, thermal cond.
- Ionic - charge transfer (nondirectional)
 - Strong \rightarrow 1-10 eV / atom pair
 - NaCl, ZnS
 - High temperature conductors
- Covalent - Hybridized bonding (directional)
 - Strong \rightarrow 1-10 eV / atom pair
 - Si, Ge, other semiconductors



CNF NanoCourses



Thin Film Technology, page 40



Surface Energy

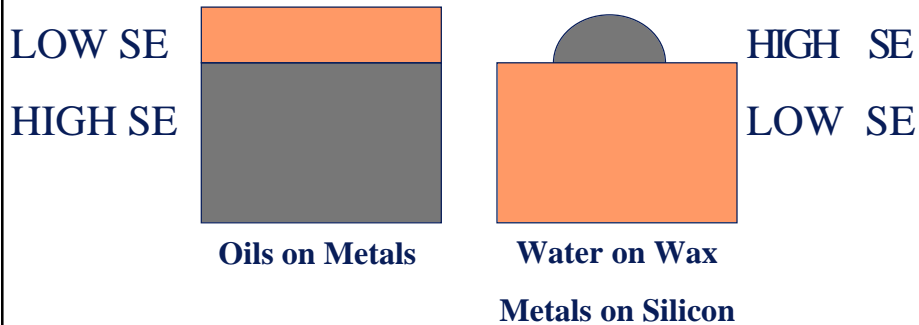

NNIN

CNF NanoCourses



Thin Film Technology, page 41

CORNELL

Surface Energy Effects

- Often thin films are more sensitive to surface effects
- **Wetting:**
 - Wets - Oil on metal
Water on dirty Si
 - Doesn't wet - Mercury on floor
Water on clean Si
- **Faceting - angular dependence of surface energy**
 - Specific growth planes during growth
 - Specific etching systems (e.g. KOH)
- **Physisorption and Chemisorption**
 - Physisorption - atoms stick to surface without a chemical reaction
 - (van der Waals)
 - Chemisorption - additional chemical forces

NNIN

CNF NanoCourses



Thin Film Technology, page 42

CORNELL

Chemical Reactivity

- Can overcome surface energy tendencies
 - Gold will ball up on Silicon Oxide
 - Titanium will react ==> good adhesion layer
- Other opportunities to overcome surface energy issues:
 - Surface bombardment
 - Reactive deposition
 - Heating



CNF NanoCourses



Thin Film Technology, page 43



Wetting Growth versus Grain Growth

Wetting Growth vs Grain Growth

Impingement Rate	High
Nucleation Density	High
Surface Energy Ratios	Low
Chemical Reactivity	High
Surface Mobility	Low
Temperature	Low



CNF NanoCourses



Thin Film Technology, page 44



Electrical Properties

- As dimensions are reduced, resistance of the interconnects increases due to the reduction in cross-sectional area
- $R = \rho L/A = \rho L/Wt$
- However for thin narrow lines, the line dimensions start to become on the order of the electron mean free path and the resistance increases
- For narrow, thin lines the ratio of the conductivity to that of the bulk conductivity is:
 - $\sigma/\sigma_b \propto t$ (where t is the thickness)
- For $W = t$ (square line)
- $R = \rho L/Wt = L/\sigma t^2 = L/\sigma_b t^3$
- **OOOPS ! (Large L, Small t, ===> R Immense !!)**

Electromigration

- The Kinetic Energy of moving electrons is sufficient to stimulate migration of the atoms in a conducting line
- Leads to electrical shorts and open circuits, device failures

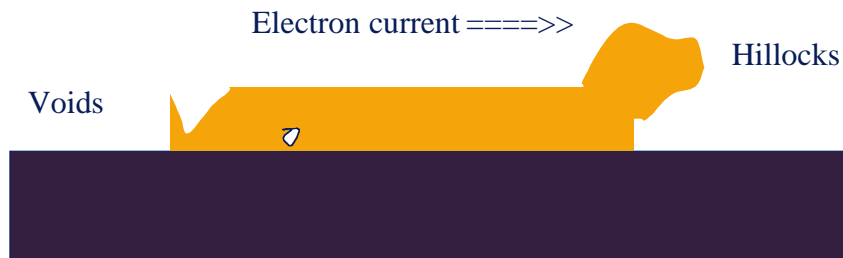

Mircostructure Effects on Electromigration



Poor electromigration resistance

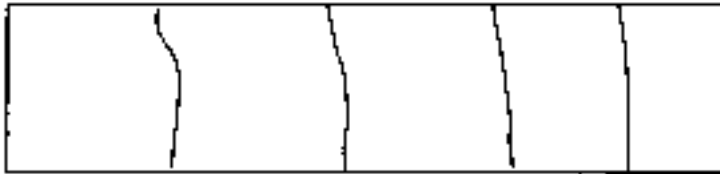

Bamboo structure = good electromigration resistance

Properties

Mechanical Properties:

- Deposited films often have high stresses in them
 - Wafers bend !!
- In as-deposited sputtered Mo films, ~ 1GPa stresses
 - Yield strength of Mo is 0.84 GPa!!!
- Thermal mismatch can cause stresses
- A film of Al is deposited on a RT Si substrate
- Upon heating to 450°C, the stress in this film is ~ 1GPa
 - Again, much greater than the yield stress
- Cracking, void growth

Microstructure Properties:

- Deposition of many materials, e.g. Mo and Ge, results in a columnar grain structure that readily absorbs water and oxygen after deposition
- Does not matter how good the vacuum was during deposition

Consequences of Surface Effects

- Islanding
- Pinholes
- Surface Roughness
- Texturing
- Faceting

4. Examples

Growth/Deposition Techniques

- Spin-On Liquid Suspension Conformal
- PVD Physical Vapor Dep (Evaporat'n) Line of Sight
- PVD Sputtering Conformal
- CVD Chemical Vapor Deposition Conformal
 - PE- Plasma Enhanced-
 - LP- Low Pressure
 - MO- Metal-Organic-
- Epitaxy Crystalline
 - MBE Molecular Beam Epitaxy
 - OMVPE Organo-Metallic Vapor Phase Epitaxy-
- Electroplating Selective



CNF NanoCourses



Thin Film Technology, page 51



a-Si:H Film Growth

- The next figure is from R.W. Collins et al., Physics of Thin Films, vol. 19, Academic Press, San Diego, CA, 1994.
- The deposition system in this case is designed for plasma-enhanced chemical vapor deposition in the remote He rf plasma configuration
- In this configuration, the SiH_4 is injected into the chamber downstream from a He plasma tube; the substrate is mounted on a heatable platform located downstream from the SiH_4 injector
- The windows on the chamber are oriented for a 70° angle of incidence at the sample surface



CNF NanoCourses



Thin Film Technology, page 52



a-Si:H Film Growth Schematic

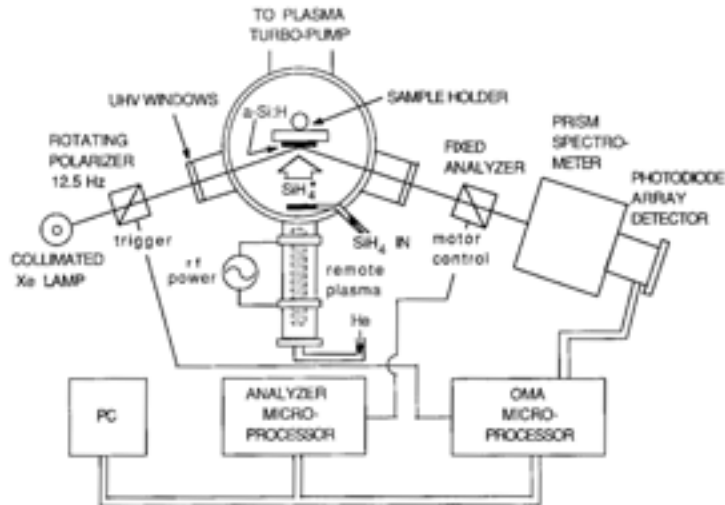

R.W. Collins et al., Physics of Thin Films, vol. 19, Academic Press, San Diego, CA, 1994



CNF NanoCourses



Thin Film Technology, page 53



PECVD a-Si:H Deposition

- The next figure is from R.W. Collins et al., Physics of Thin Films, vol. 19, Academic Press, San Diego, CA, 1994.
- Results for one- and two-layer models are included (see inset)
- Microstructural parameters obtained in the fits using the one-layer model for $t < 12$ s and using the two-layer model for $t \geq 12$ s are shown on page 14



CNF NanoCourses



Thin Film Technology, page 54



PECVD a-Si:H Deposition Plot

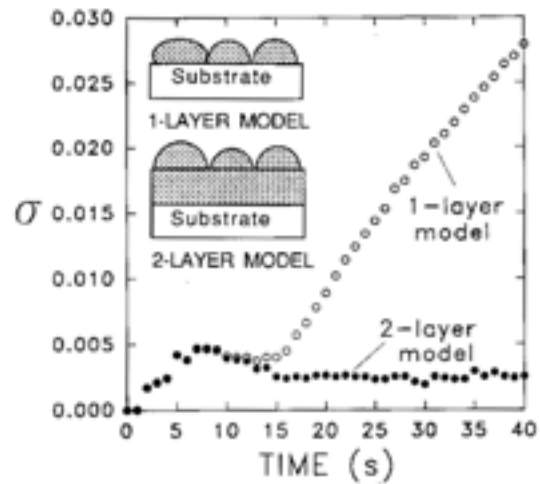

R.W. Collins et al., Physics of Thin Films, vol. 19, Academic Press, San Diego, CA, 1994



CNF NanoCourses



Thin Film Technology, page 55



Summary

- There are MANY criteria for successful thin film processing
- Many parameters, techniques, materials
- Choices are made based on the desired film properties



CNF NanoCourses



Thin Film Technology, page 56



NanoCourses 2002, Part 3

Practical Thin Film Technology

The Flatland of Thin Films
Puttin' 'em on and Takin' 'em off

Evaporation for the Production of Thin Films by Michael Skvarla

Presented by the
CNF Technical Staff
for the education of CNF Users,
Potential Users, and Industrial Sponsors



CNF NanoCourses



Thin Film Technology, page 57



Growth/Deposition Techniques

- | | | |
|------------------|--|----------------------|
| • Spin-On | Liquid Suspension | Conformal |
| • PVD | Physical Vapor Deposition
Evaporation | Line of Sight |
| • PVD | Sputtering (Scattering) | Conformal |
| • CVD | Chemical Vapor Deposition | Conformal |
| • PE- | Plasma Enhanced- | |
| • LP- | Low Pressure | |
| • MO- | Metal-Organic- | |
| • Epitaxy | | Crystalline |
| • MBE | Molecular Beam Epitaxy | |
| • OMVPE | Organo-Metallic Vapor Phase Epitaxy- | |
| • Electroplating | | |



CNF NanoCourses



Thin Film Technology, page 58



Physical Vapor Deposition Techniques

- **Physical Vapor Deposition**
 - Thermal and electron beam evaporation
 - Sputtering
 - Reactive evaporation / Sputtering
 - Co-Evaporation / Sputtering (alloys, compounds)

Requirements for Evaporation

- Vacuum
- Source material
 - Reasonable vapor pressure at a reasonable temperature
- Energy input to vaporize material
- Transport to the sample
- Sample holder (variable temp?)
- Preferably a shutter
- Preferably a thickness/rate monitor
- Condense, migrate, react ===== > Layer growth
- Post-deposition processing (anneal, etc.)

Vacuum System Schematic

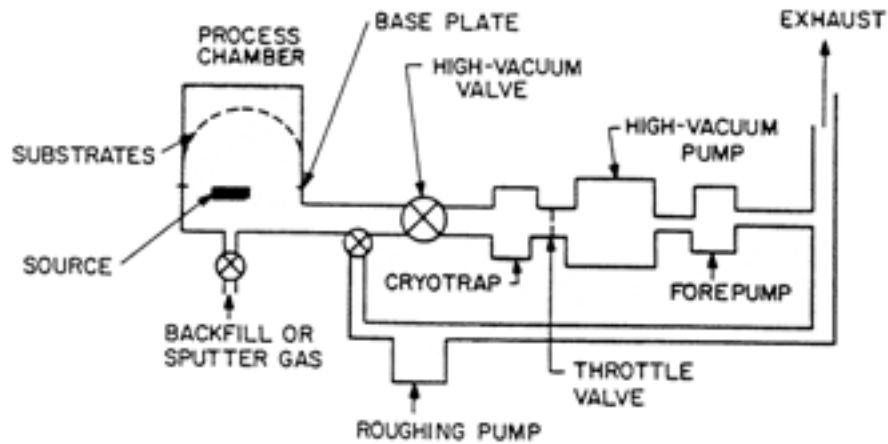

Schematic view of a high-vacuum chamber with substrates mounted in a planetary substrate support above the source



CNF NanoCourses



Thin Film Technology, page 61



How Good Should the Vacuum Be?

- At 10^{-6} Torr, you'll deposit roughly one monolayer per second of crud (e.g. water vapor)
- May or may not be critical for your application



CNF NanoCourses



Thin Film Technology, page 62



Deposition Rate

- A reasonable deposition rate requires that the vapor pressure of the material during evaporation should be above 10 mT
- Deposition rate at the sample depends on the geometry
 - Usually a few to many nanometers per second ($\text{\AA}/\text{s}$)

Vapor Pressure Curves

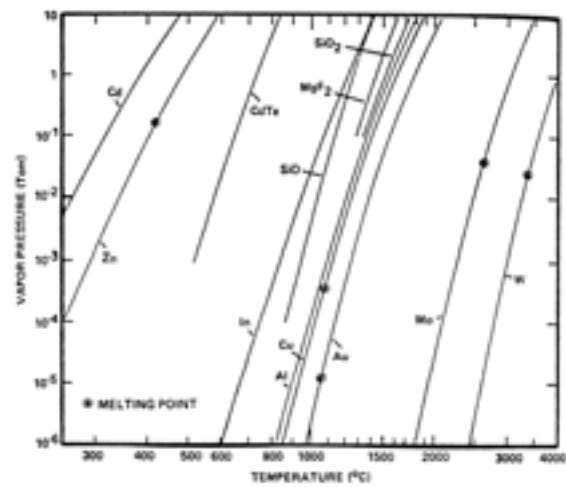

Equilibrium vapor pressures of several elements and inorganic compounds of interest in electronics related applications

Evaporation Sources

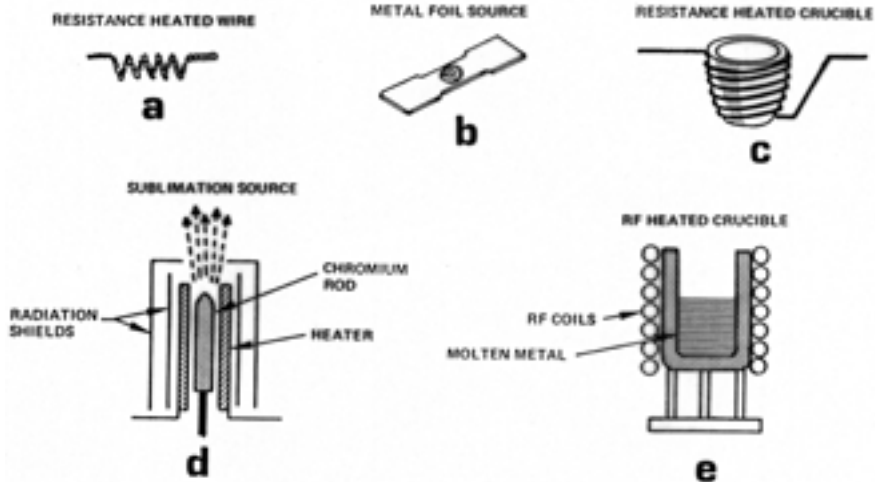

CNF NanoCourses



Thin Film Technology, page 65



Temperatures and Support Materials Used in the Evaporation of the Elements

Element and predominant vapor species	Temp. °C		Support materials		Remarks
	mp	$\mu^{\circ} = 10^{-4}$ Torr	Wire, foil	Crucible	
Aluminum (Al)	933	1220	W	C, BK, TiB ₂ /BN	Wet all materials readily and tends to creep out of anodes. Always with W foil except with carbon. Slender crucibles preferred. Polytetrafluoro vapor, $\mu = 2 \times 10^{-4}$. Evaporate temperatures above mp.
Antimony (Sb), (Sb ₂)	630	630	Mo, Ti, Ni	Oxides, BK, metals, C	Polytetrafluoro vapor, $\mu = 2 \times 10^{-4}$. Evaporate temperatures above mp.
Arsenic (As), (As ₂)	605	-200	Oxides, C	Polytetrafluoro vapor, $\mu = 2 \times 10^{-4}$. Sublimates but requires temperatures above 200°C.
Boron (B)	2100	600	W, Mo, Ti, Ni, Fe	Metals	Wet refractory metals without alloying. Reacts with most oxides at elevated temperatures. Wet refractory metals. Feeds, particularly B ₂ O ₃ dust. Vapors are toxic.
Barium (Ba)	1280	1220	W, Mo, Ti, Ni, Fe	C, refractory oxides	Wet refractory metals. Feeds, particularly B ₂ O ₃ dust. Vapors are toxic.
Beryllium (Be)	2775	675	W, Mo, Ti, Ni, Fe	Oxides, C, metals
Bismuth (Bi)	271	2000	C	Deposits from carbon supports are probably not pure bismuth.
Calcium (Ca)	842	260	W, Mo, Ti, Fe, Ni	Oxides, refractory metals	Feeds continuously requires high temperatures. Sublimates. Wet deposits of Cd emit vacuum system.
Calcium (Ca)	842	600	W	Al ₂ O ₃
Carbon (C), (C), (C ₂)	-3500	-2000	Carbon arc or electron beam heated evaporation. $\mu = 1$.
Chromium (Cr)	1900	1400	W, Ti	High evaporation rates without melting. Sublimation from evaporation heated Cr rods preferred. Cr electrodes are formed. Cr electrodes are used as cathodes in vacuum tubes.
Cobalt (Co)	1495	1320	W	Al ₂ O ₃ , BeO	Wet all refractory metals. Always with W except should not weigh more than 30% of filament to limit destruction. Small sublimation rates possible.
Copper (Cu)	1084	1200	W, Mo, Ti	Mo, C, Al ₂ O ₃	Practically no interaction with refractory materials. Mo preferred for crucibles because it can be machined and machine turn well.
Gallium (Ga)	30	1120	BeO, Al ₂ O ₃	Always with refractory metals. The anodes are etched above 1000°C.
Germanium (Ge)	940	1420	W, Mo, Ti	W, C, Al ₂ O ₃	Wet refractory metals but low solubility in W. Form films by electron-gun evaporation.
Gold (Au)	1063	1420	W, Mo	Mo, C	Reacts with Ti, with W and Mo. Mo crucibles last for several evaporations.
Indium (In)	156	600	W, Mo	Mo, C	Mo leads preferred.
Iron (Fe)	1538	1200	W	BeO, Al ₂ O ₃ , SiO ₂	Always with all refractory metals. Change steel and weigh more than 30% of W filament to limit destruction. Small sublimation rates possible.
Lead (Pb)	327	710	W, Mo, Ni, Fe	Metals	Does not wet refractory metals.
Magnesium (Mg)	650	600	W, Mo, Ti, Ni, Fe	Fe, C	Sublimates.
Manganese (Mn)	1244	600	W, Mo, Ti	Al ₂ O ₃	Wet refractory metals.

Temperatures and Support Materials Used in the Evaporation of the Elements
(Continued)

Element and predominant vapor species	Temp, °C		Support materials		Remarks
	mp	p° at 10 ⁻⁴ Torr	Wire, foil	Crucible	
Molybdenum (Mo)	2620	2030	Small rates by sublimation from Mo foil. Electron-gun evaporation preferred.
Nickel (Ni)....	1450	1030	W, W foil lead with Al ₂ O ₃	Substoichiometric oxides	Alloys with substoichiometric oxides. Anneal charge must be limited. Small rates by sublimation from Ni foil or wire. Electron-gun evaporation preferred.
Palladium (Pd)	1550	1400	W, W foil lead with Al ₂ O ₃	Al ₂ O ₃	Alloys with substoichiometric oxides. Small sublimation rates possible.
Platinum (Pt)	1770	2100	W	TiO ₂ , SiO ₂	Alloys with substoichiometric oxides. Multicomponent W wire often short evaporation times. Electron-gun evaporation preferred.
Rhodium (Rh)	1960	2040	W	TiO ₂ , SiO ₂	Small rates by sublimation from Rh foil. Electron-gun evaporation preferred.
Rubidium (Rb, Rb ₂) $\alpha = 1.8 \times 10^{-4}$	203	240	Mo, Ta, stainless steel 304	Mo, Ta, C, Al ₂ O ₃	Wire of various materials. Wall deposits spoil vacuum system. Toxic. $\alpha = 1$.
Silicon (Si)....	1410	1200	FeO, SiO ₂ , TiO ₂ , C	Substoichiometric oxides are attacked by molten Si and films are contaminated by SiO ₂ . Small rates by sublimation from Si filament. Electron-gun evaporation gives poorest films.
Silver (Ag)....	961	1000	Mo, Ta	Mo, C	Does not wet W. Mo crucibles are very durable sources.
SrO (Sr)	770	540	W, Mo, Ta	Mo, Ta, C	Wire of refractory metals without alloying.
Tantalum (Ta)	3000	3000	Evaporation by resistance heating of touching Ta wire, or by drawing an arc between Ta rods. Electron-gun evaporation preferred.
Tellurium (Te)	450	370	W, Mo, Ta	Mo, Ta, C, Al ₂ O ₃	Wets all refractory metals without alloying. Concomitant vacuum system. Toxic. $\alpha = 0.4$.
Ti (Ti).....	257	1000	W, Ta	C, Al ₂ O ₃	Wets and attacks Mo.
Titanium (Ti)	1790	1700	W, Ta	C, Ta, Ti	Alloys with substoichiometric oxides. Small sublimation rates from resistance heated rods or wires. Electron-gun evaporation preferred.
Tungsten (W)	3380	3030	Evaporation by resistance heating of touching W wire, or by drawing an arc between W rods. Electron-gun evaporation preferred.
Vanadium (V)	1900	1800	Mo, W	Mo	Wets Mo without alloying. Alloys slightly with W. Small sublimation rates possible.
Zinc (Zn)....	420	340	W, Ta, Ni	Fe, Al ₂ O ₃ , C, Mo	High sublimation rates. Wets refractory metals without alloying. Wall deposits spoil vacuum system.
Zirconium (Zr)	1850	1400	W	Wets and slightly alloys with W. Electron-gun evaporation preferred.

Electron Beam Evaporation

- Usually “better” than thermal evaporation
- Less contamination from the source holder
 - Only the desired material is heated
- More suitable for higher melting point materials (T~3000°C)
- Typically better vacuum
- Usually higher deposition rates
- Better control of deposition rates
- More expensive equipment
- Maybe slower turnaround

Schematic of an E-Beam Gun

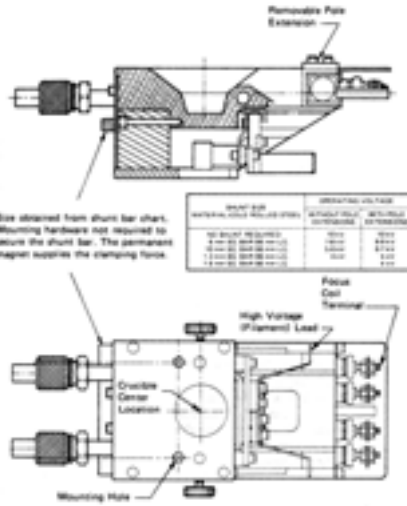

Thickness Uniformity

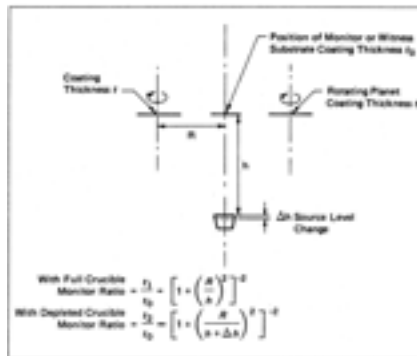

Deposition Rate
is a function of
Sample Position

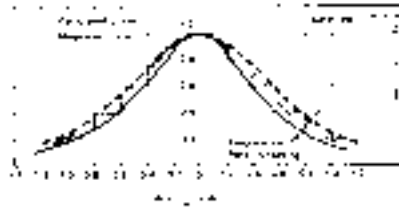

Alloy Evaporation

- If you want to evaporate an alloy from a single source, the two elements had better have similar vapor pressures
 - (Say no more than 2 orders of magnitude difference at the desired evaporation temperature)
- But don't expect an extremely uniform composition
 - (E.g. possibly zone refining effects)
- Co-evaporation or sputtering is generally preferable for alloys
- For some oxides, you might consider reactive evaporation, but it is rarely used
- Difficult to control?



CNF NanoCourses



Thin Film Technology, page 71



Thickness and Deposition Rate Control

- Straightforward to measure thickness after film is deposited
- There are several thickness profilers (Alpha Step) throughout CNF
- It's a good idea to place an additional substrate (glass slide?) suitably masked to give an independent thickness measurement
- As we discussed in the Thin Film section, deposition rate can have a significant effect on many film properties
- You can crudely determine rate with a timer after the fact
- Much better to use a film thickness monitor



CNF NanoCourses



Thin Film Technology, page 72



Thickness and Deposition Rate Control

- Must be calibrated for each material and geometry
- Typically good for about 20 μm of Al or 3 μm of Au

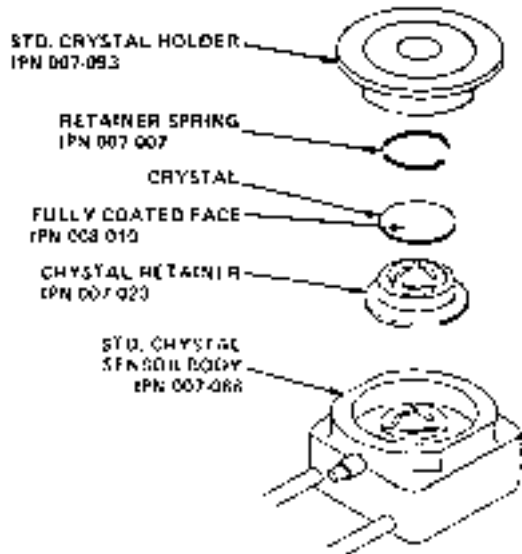

NNIN

CNF NanoCourses



Thin Film Technology, page 73

CORNELL

Lift-Off



will lift-off

won't lift-off

high aspect ratio patterns

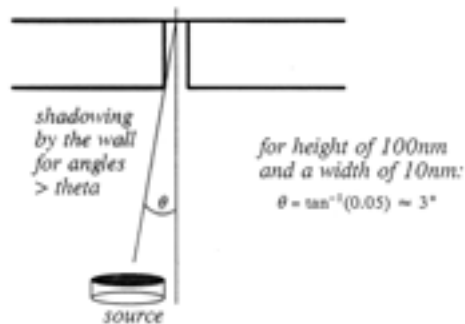

NNIN

CNF NanoCourses



Thin Film Technology, page 74

CORNELL

Lift-Off

- A valuable research procedure
- Ethan Swint (1999)

Top Metal ----->

Resist Profile ----->

Substrate Metal ----->

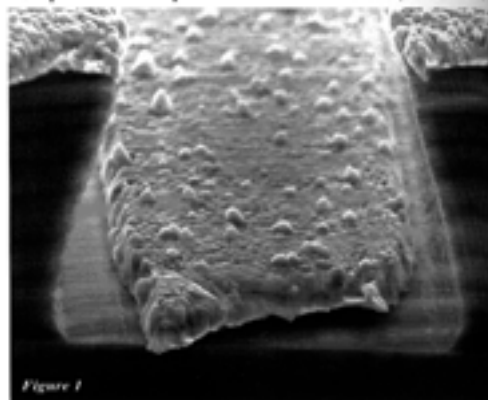

Summary

- Evaporation is a line-of-sight deposition
- Appropriate to electron beam or photolithography
- A valuable research procedure that can produce films with superior properties with device dimensions from a few nanometers to many millimeters

NanoCourses 2004, Part 3

Practical Thin Film Technology

The Flatland of Thin Films
Puttin' 'em on and Takin' 'em off

Evaporation for the Production of Thin Films by Michael Skvarla

Presented by the
CNF Technical Staff
for the education of CNF Users,
Potential Users, and Industrial Sponsors



CNF NanoCourses



Evaporation, page 1



Growth/Deposition Techniques

- Spin-On Liquid Suspension Conformal
- **PVD** **Physical Vapor Deposition** **Line of Sight**
Evaporation
- PVD Sputtering (Scattering) Conformal
- CVD Chemical Vapor Deposition Conformal
 - PE- Plasma Enhanced-
 - LP- Low Pressure
 - MO- Metal-Organic-
- Epitaxy Crystalline
 - MBE Molecular Beam Epitaxy
 - OMVPE Organo-Metallic Vapor Phase Epitaxy-
- Electroplating



CNF NanoCourses



Evaporation, page 2



Physical Vapor Deposition Techniques

- **Physical Vapor Deposition**
 - Thermal and electron beam evaporation
 - Sputtering
 - Reactive evaporation / Sputtering
 - Co-Evaporation / Sputtering (alloys, compounds)



Requirements for Evaporation

- Vacuum
- Source material
 - Reasonable vapor pressure at a reasonable temperature
- Energy input to vaporize material
- Transport to the sample
- Sample holder (variable temp?)
- Preferably a shutter
- Preferably a thickness/rate monitor
- Condense, migrate, react ===== > Layer growth
- Post-deposition processing (anneal, etc.)



Vacuum System Schematic

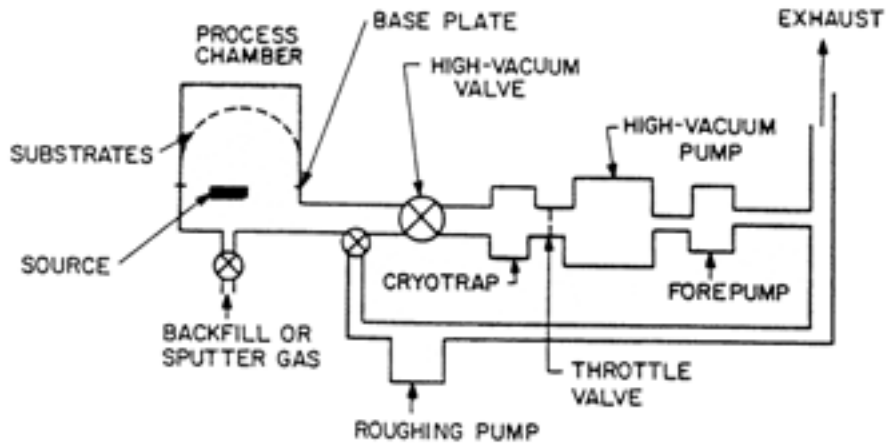

Schematic view of a high-vacuum chamber with substrates mounted in a planetary substrate support above the source

How Good Should the Vacuum Be?

- At 10^{-6} Torr, you'll deposit roughly one monolayer per second of crud (e.g. water vapor)
- May or may not be critical for your application

Deposition Rate

- A reasonable deposition rate requires that the vapor pressure of the material during evaporation should be above 10 mT
- Deposition rate at the sample depends on the geometry
 - Usually a few to many nanometers per second ($\text{\AA}/\text{s}$)

Vapor Pressure Curves

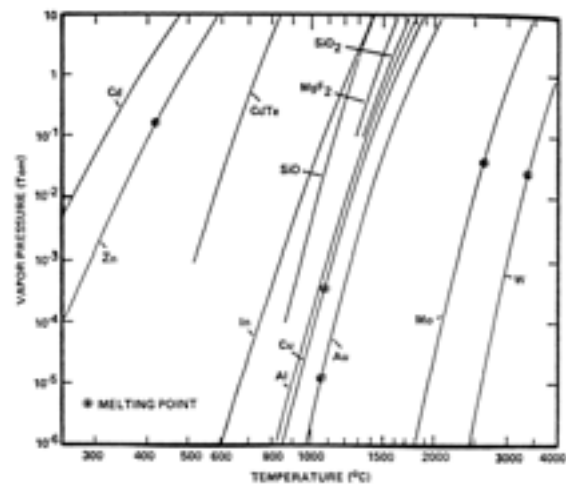

Equilibrium vapor pressures of several elements and inorganic compounds of interest in electronics related applications

Evaporation Sources

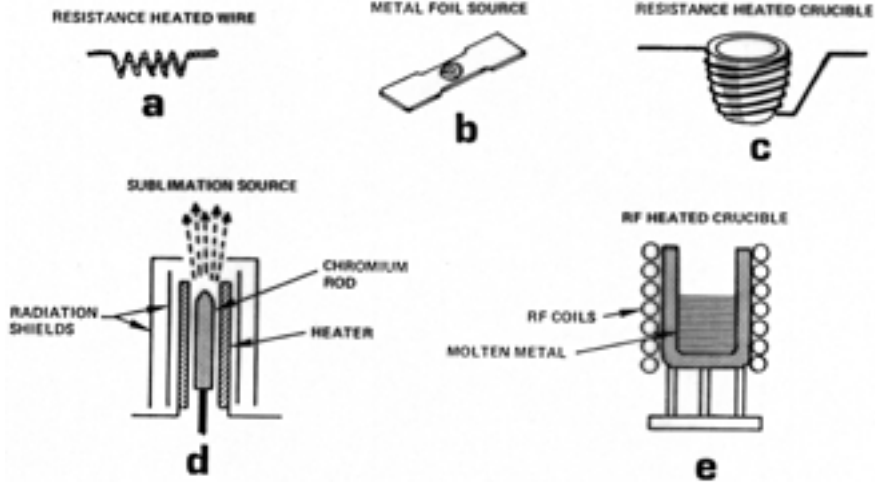

CNF NanoCourses



Evaporation, page 9







Temperatures and Support Materials Used in the Evaporation of the Elements

Element and predominant vapor species	Temp. °C		Support materials		Remarks
	mp	$\rho^a \times 10^{-3}$ Y/cm ³	Wire, foil	Crucible	
Aluminum (Al)	933	2700	W	C, BK, TiB ₂ /W	Wet all materials readily and tends to creep out of crucibles. Always with W and rarely with carbon. Metallic crucibles preferred.
Antimony (Sb), (Sb ₂)	630	630	Mo, Ti, Ni	Oxides, BK, metals, C	Polymers evaporate at 4-5% Evaporate temperatures above 500°C.
Arsenic (As), (As ₂)	605	~300	Oxides, C	Polymers evaporate at 5-10% 4-10%. Sublimates for evaporation temperatures above 500°C.
Boron (B)	2100	600	W, Mo, Ti, Ni, Fe	Metals	Wet refractory metals without etching. Always with most oxides at elevated temperatures.
Beryllium (Be)	1280	1800	W, Mo, Ti, Ni, Fe	C, refractory oxides	Wet refractory oxides. Tends to form BeO.
Bismuth (Bi), (Bi ₂)	271	970	W, Mo, Ti, Ni	Oxides, C, metals	Vapors are toxic.
Barium (Ba)	1100	3600	C	Deposits from carbon crucibles are probably not pure barium.
Calcium (Ca)	850	300	W, Mo, Ti, Fe, Ni	Oxides, metals	Thin crucibles require high evaporation rates. Sublimates. Wall deposits of CaO coat crucible interior.
Carbon (C), (C ₂), (C ₃), (C ₄), (C ₆)	3500	~2000	ALN	Carbon arc or electric furnace. High evaporation rates without melting. Sublimates from radiation-heated Ti tube geometries. Or electrocrucibles are used to reduce hydrogen.
Cerium (Ce)	1065	1300	W	Al ₂ O ₃ , BeO	Always with W. Always should not weigh more than 10% of filament to limit distortion. Small sublimating mass available.
Copper (Cu)	1083	1300	W, Mo, Ti, Fe	Mo, Ti, ALN	Formally an evaporator with refractory crucibles. Mo preferred for crucibles because it can be machined and crucibles last well.
Chromium (Cr)	2100	7100	BeO, Al ₂ O ₃	Always with refractory oxides. The oxides are attacked above 1000°C.
Cyanogen (C ₂ N ₂)	~400	1000	W, Mo, Ti	W, C, ALN	Wet refractory metals but low solubility in W. Favor films by nitrogen gas evaporation.
Gold (Au)	1063	1930	W, Mo	Mo, C	Always with Ti, W, Mo and Mo. Mo crucibles last for several evaporation.
Iodine (I ₂)	184	4900	W, Mo	Mo, C	Mo films preferred.
Iron (Fe)	1538	7700	W	BeO, Al ₂ O ₃ , TiO ₂	Always with all refractory metals. Always should not weigh more than 10% of W filament to limit distortion. Small sublimating mass possible.
Lead (Pb)	327	710	W, Mo, Ti, Fe	Metals	Always with refractory oxides. Toxic.
Magnesium (Mg)	650	1740	W, Mo, Ti, Ni	Fe, C	Sublimates.
Manganese (Mn)	1246	510	W, Mo, Ti	Al ₂ O ₃	Wet refractory metals.

Material	Evaporation rate (Å/s)		Temperature (°C)		Notes
	Thermal	Electron Beam	Thermal	Electron Beam	
Aluminum	~10	~100	~1500	~2500	Electron beam evaporation is preferred for Al.
Chromium	~10	~100	~1500	~2500	Electron beam evaporation is preferred for Cr.
Gold	~10	~100	~1500	~2500	Electron beam evaporation is preferred for Au.
Iron	~10	~100	~1500	~2500	Electron beam evaporation is preferred for Fe.
Nickel	~10	~100	~1500	~2500	Electron beam evaporation is preferred for Ni.
Palladium	~10	~100	~1500	~2500	Electron beam evaporation is preferred for Pd.
Platinum	~10	~100	~1500	~2500	Electron beam evaporation is preferred for Pt.
Silver	~10	~100	~1500	~2500	Electron beam evaporation is preferred for Ag.
Titanium	~10	~100	~1500	~2500	Electron beam evaporation is preferred for Ti.
Tungsten	~10	~100	~1500	~2500	Electron beam evaporation is preferred for W.
Zinc	~10	~100	~1500	~2500	Electron beam evaporation is preferred for Zn.

Electron Beam Evaporation

- Usually “better” than thermal evaporation
- Less contamination from the source holder
 - Only the desired material is heated
- More suitable for higher melting point materials ($T \sim 3000^\circ\text{C}$)
- Typically better vacuum
- Usually higher deposition rates
- Better control of deposition rates
- More expensive equipment
- Maybe slower turnaround

Schematic of an E-Beam Gun

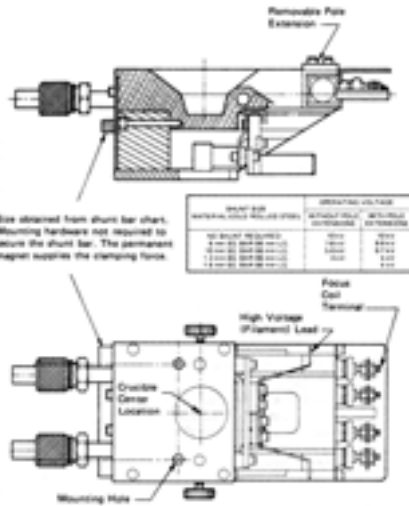

Thickness Uniformity

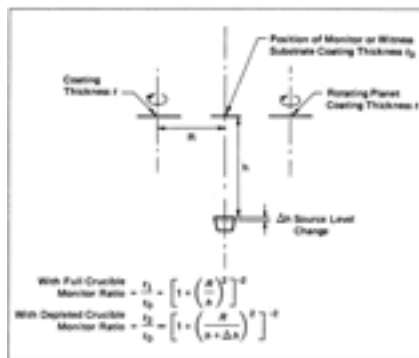

Deposition Rate
is a function of
Sample Position

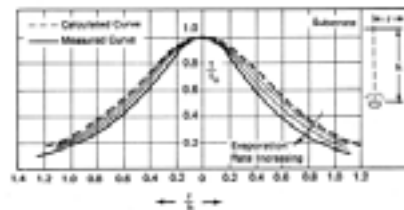

Alloy Evaporation

- If you want to evaporate an alloy from a single source, the two elements had better have similar vapor pressures
 - (Say no more than 2 orders of magnitude difference at the desired evaporation temperature)
- But don't expect an extremely uniform composition
 - (E.g. possibly zone refining effects)
- Co-evaporation or sputtering is generally preferable for alloys
- For some oxides, you might consider reactive evaporation, but it is rarely used
- Difficult to control?



CNF NanoCourses



Evaporation, page 15



Thickness and Deposition Rate Control

- Straightforward to measure thickness after film is deposited
- There are several thickness profilers (Alpha Step) throughout CNF
- It's a good idea to place an additional substrate (glass slide?) suitably masked to give an independent thickness measurement
- As we discussed in the Thin Film section, deposition rate can have a significant effect on many film properties
- You can crudely determine rate with a timer after the fact
- Much better to use a film thickness monitor



CNF NanoCourses



Evaporation, page 16



Thickness and Deposition Rate Control

- Must be calibrated for each material and geometry
- Typically good for about 20 μm of Al or 3 μm of Au

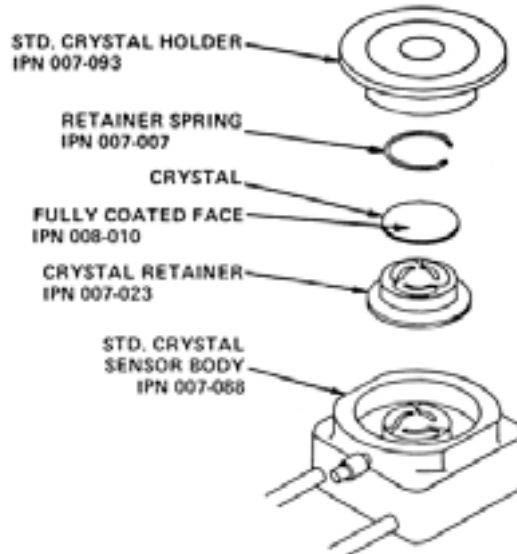

Lift-Off

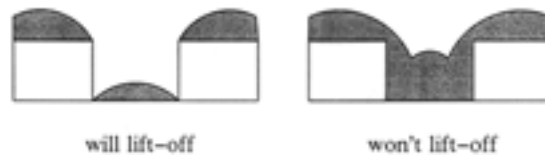

high aspect ratio patterns

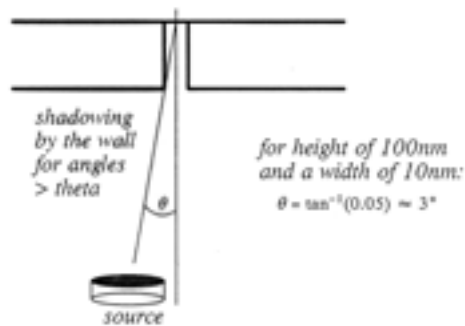

Lift-Off

- A valuable research procedure
- Ethan Swint (1999)

Top Metal ----->

Resist Profile ----->

Substrate Metal ----->

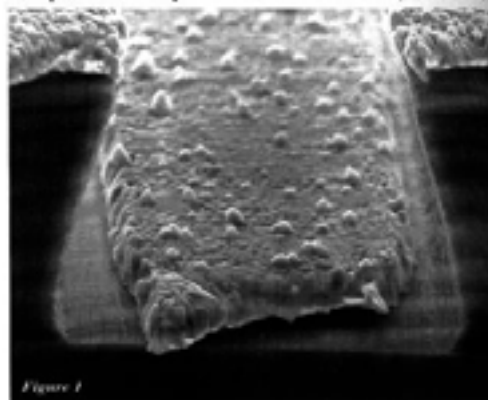

Summary

- Evaporation is a line-of-sight deposition
- Appropriate to electron beam or photolithography
- A valuable research procedure that can produce films with superior properties with device dimensions from a few nanometers to many millimeters

NanoCourses 2004, Section 3

Practical Thin Film Technology

**The Flatland of Thin Films
Puttin' 'em on and Takin' 'em off**

Dry Etching for Pattern Transfer

by
Meredith Metzler

Presented by the
CNF Technical Staff
for the education of CNF Users,
Potential Users, and Industrial Sponsors



CNF NanoCourses



Dry Etch, page 1



Outline

- **Pattern Transfer**
- **Plasmas for Materials Processing**
- **Mechanisms Associated with Plasma Etching**
- **Plasma Etching Tools and Methods**
- **Etch Processes**
- **Artifacts and Effects**



CNF NanoCourses



Dry Etch, page 2



Pattern Transfer

Also known as Etching



Pattern Transfer

- Transfer (etch) pattern defined by resist layer into substrate
- Unprotected areas removed
- “Resist” is typically photoresist but may be any other patterned layer
- Chemical processes
- Physical processes
- Wet or dry

Original Structure

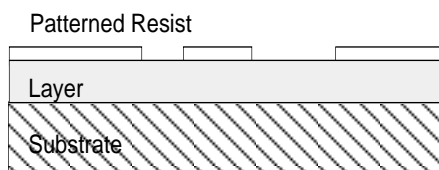

Etched Structure

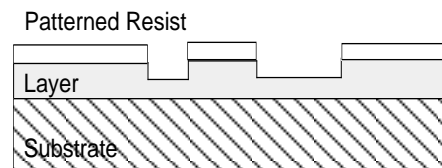

General "Subtractive" Processing

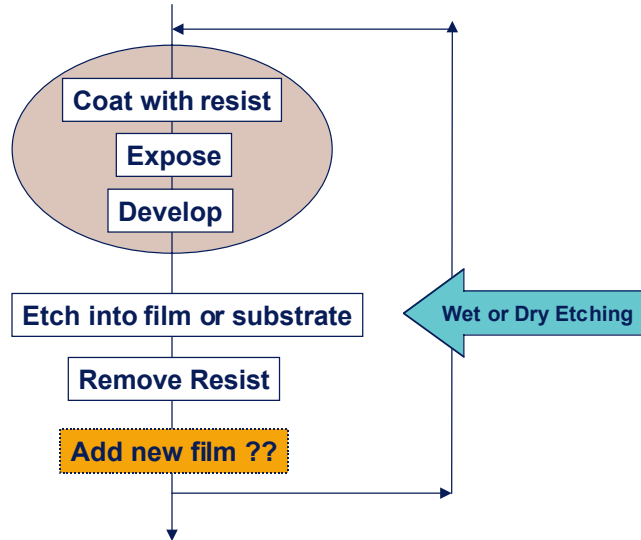

Dry Etching Examples

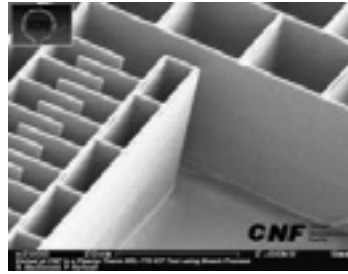
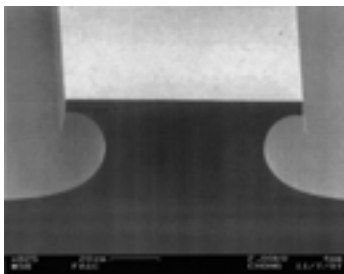
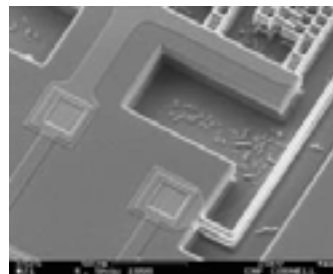
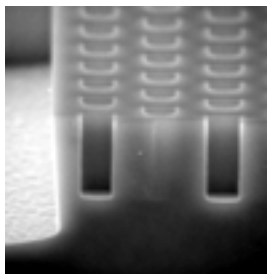

Why Not Wet Etching?

- Many viable wet etching processes
 - Acids, etc
- Dimensional control
- Commonly used for larger structures or exotic films
- **Not all wet processes are non-directional and not all dry processes are directional, but dry processes generally give more control**

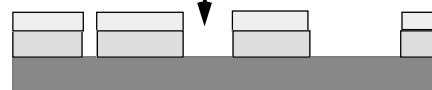
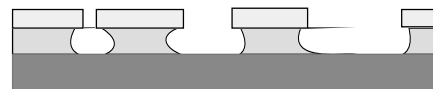
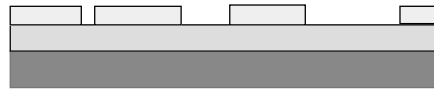

More Dry Etching Examples

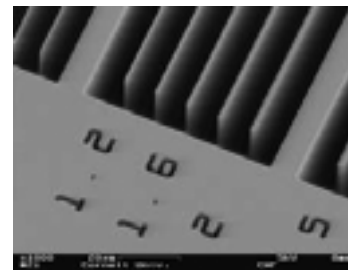
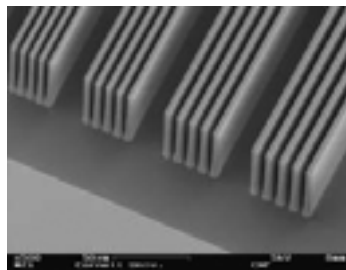
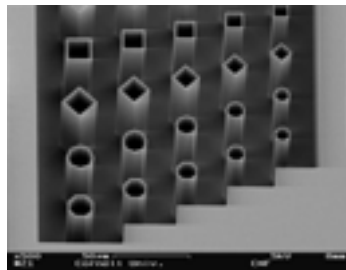

Dry Pattern Transfer Terms

- **Dry etching**
 - Generic term covering everything using a gas in vacuum to etch, including ion beams
- **Plasma etching**
 - Generic term covering dry etching involving plasma excitation
 - Essentially most dry etching but not all
- **Reactive ion etching**
 - The specific type of plasma etching we most commonly use
 - More later



Plasmas for Materials Processing

What is a plasma, why do we use it,
and how do we make it?



What is a Plasma?

- A plasma is an ionized gas
 - Ions
 - Electrons
 - Molecular fragments
- Electrically neutral
- Generally electrically excited
 - Various types of EM excitation
- Weakly ionized plasma
 - Only a small fraction excited species
 - Small but important



CNF NanoCourses



Dry Etch, page 11



CNF Processes Using Plasmas

- DC, RF, and LF Plasmas for Deposition
 - Sputtering
 - Plasma CVD
- DC, RF, and LF Plasmas for Etching
 - DC for Ion Milling and CAIBE
 - Reactive Ion Etching (RIE)
 - Magnetically Enhanced Ion Etching (MIE)
 - Electron Cyclotron Resonance Etching (ECR)
 - Inductively Coupled Plasma Etching (ICP)



CNF NanoCourses



Dry Etch, page 12



Role of the Plasma

- Gas by itself is not very reactive
 - $\text{CF}_4 + \text{Si} = \text{zip}$
 - $\text{CF}_4 \text{ plasma} + \text{Si} = \text{etching}$
- Create ions
- Create electrons
- Create excited species and radicals

- Plasma provides energy to get over the activation barrier or lowers the activation barrier



Weakly Ionized Plasmas: the Plasma Discharge

- Electrically driven
- Charge particle collisions (e^-) with neutral gas molecules are important
- Surface losses at boundaries are important
- Ionization of neutrals sustains plasma in steady state
- Electrons are not in thermal equilibrium with ions
- Weakly ionized and excited
 - Generally $<1\%$ ions and radicals

- Energy is capacitively or inductively applied



Plasma Body and Sheaths

- The body is a perfect conductor
 - Equipotential
- All potential drop is across these sheaths (dark spaces) at each electrode
- Electrons can escape more rapidly at edges than ions
- A potential barrier develops to suppress electron escape
- Ions are accelerated by the sheath to the electrodes
- **Plasma body is more positive than either electrode !!!**

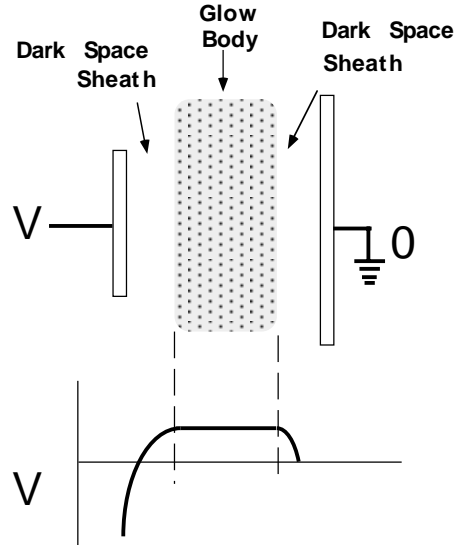

NNIN

GNF NanoCourses



Dry Etch, page 15

CORNELL

Electrode Area and Sheath Voltages

- Sheath voltages not necessarily the same on both electrodes
- Depends inversely on the **4th power** of the electrode area
- Smaller electrode has highest bias and most voltage drop across the sheath
 - Highest energy ion bombardment
- In most RIE processes, sample is on the smaller electrode, getting significant high energy ion bombardment
 - This is typically also the cathode, the driven electrode

NNIN

GNF NanoCourses



Dry Etch, page 16

CORNELL

Schematic

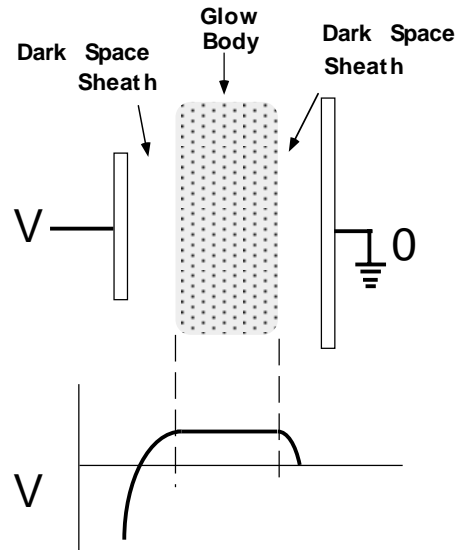

What Do These Ions Do to the Material?

- Samples on the electrodes (either electrode) get bombarded by ions
- Inert Ions bombard the surface supplying enough energy to break chemical bonds and/or dislodge atoms
- Reactive Ions bombard the surface and bond with atoms creating **volatile** species
 - Various mechanisms
- Etched atoms, ions and molecules are then pumped out of the chamber
- Ion stimulated chemistry

DC Diode Plasmas

- Introduction of a large DC bias across two plates of unspecified geometry with a low pressure gas between them (.001 - 1 Torr)
- Voltage is greater than the breakdown voltage causing an ionization cascade that leads to a plasma
- Generally used for deposition and inert milling of materials
- Requires conducting electrodes and samples

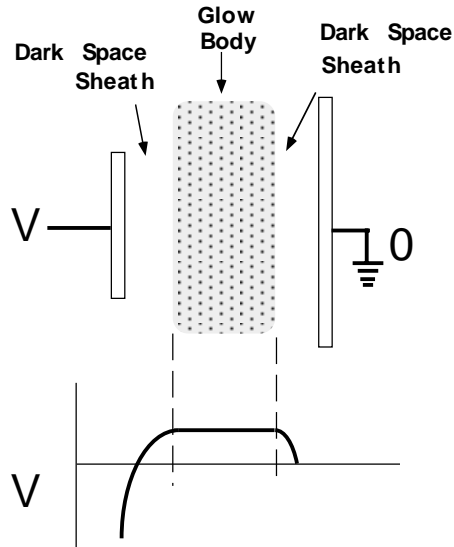

RF Diode Plasmas

- RF power is driven across two plates
- Electrons oscillate at the RF frequency causing ionization
- Electrodes not necessarily conductors
- Constraint: No time average current of the plasma
- But the electrons respond faster than ions
- =====> a DC offset (bias) results so that the positive and negative swing voltages are unequal but the positive and negative swing currents are equal

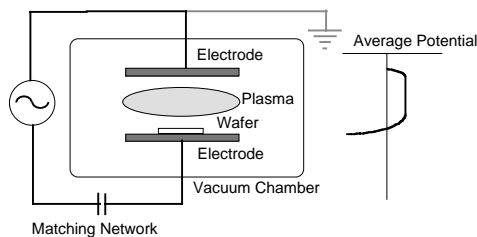

RF Plasma Potentials

- Concerned with three potentials
 - (ave) Plasma Potential (V_p)
 - Body of plasma
 - RF input voltage (V_{rf})
 - (ave) DC bias (V_{dc})
- In RF diode Low Pressure RIE
 - Sample on Driven Electrode
 - Ave ion energy = V_{dc}
 - Instantaneous Ion energy at cathode = $V_{rf} - V_p$
 - Instantaneous ion energy at anode = V_p

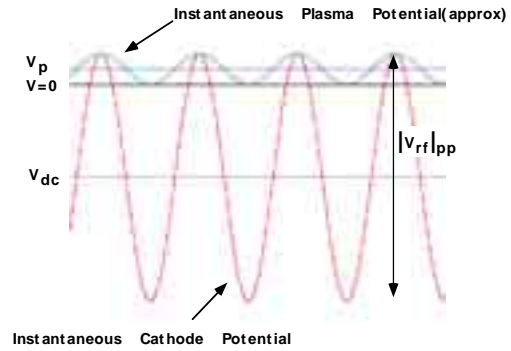

Mechanisms Associated With Plasma Etching

Etching Mechanisms

- **Range of mechanisms**
 - Completely chemical (spontaneous)
 - Completely physical (ion bombardment)
 - Everything in between
- **All important to various extents in different processes**
 - Control by choice of configuration and process parameters



Directionality

- **For the most part, ion bombardment is directional**
- **Ion stimulated chemical reactions result in directional etching!!**
 - One of several mechanisms that promote directionality
- **Isotropic and anisotropic are poor word choices**



Physical Etching

- “Inert” Ions bombard the surface
 - Sputter threshold ~ 10 eV
- Ions dislodge atoms from surface
- Surface and sub-surface damage
- Momentum transfer--no chemistry
- Sputtered atoms generally re-deposited elsewhere
- A significant part of many etch processes

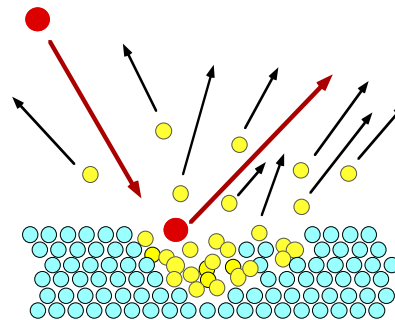

NNIN

GNF NanoCourses



Dry Etch, page 25

CORNELL

Ion Bombardment Effects

- Adverse effects of excessive physical sputtering
- Caused by
 - Re-deposition of material
 - Angular dependence
 - Sputter yield

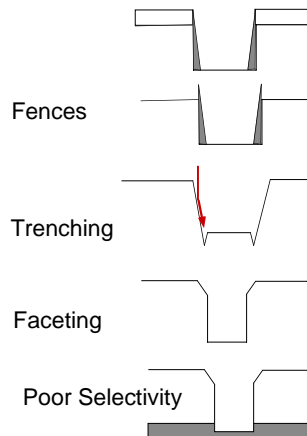

NNIN

GNF NanoCourses



Dry Etch, page 26

CORNELL

Chemical Etching--Volatile Products

- Removal is enhanced if you can do chemistry and make a volatile reaction product
 - i.e. a reaction product with a high vapor pressure so it will desorb and stay in gas phase
 - Desorb either naturally or under ion bombardment
 - e.g. F atoms reacting to make SiF_4 , a gas

GaAs	Not Volatile	Volatile
Aluminum	Not Volatile	Volatile
Copper	Not Volatile	Not Volatile

Ion Stimulated Chemical Reactions

- Gas adsorbs but does not fully react
- Ion bombardment supplies reaction energy

Alternatively:

- Gas reacts fully but doesn't have enough energy to desorb
- Ion bombardment supplies desorption energy

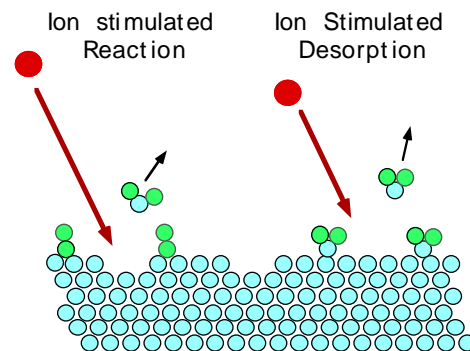

Plasma Passivation and Removal

- Etch reaction may leave something behind
 - Often a carbon or fluorocarbon residue
- May arrest reaction
- Ion bombardment can remove this passivation on **exposed** surfaces
 - Exposed means exposed to ion bombardment
 - Sidewalls are generally NOT exposed
- A mechanism to prevent sidewall etching

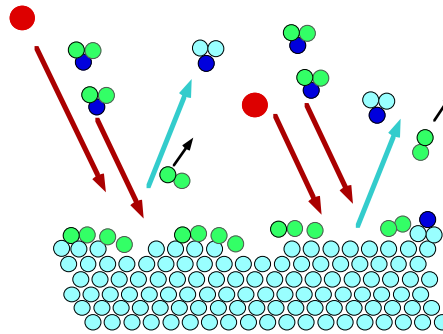

Ion Stimulated Removal of Passivation

- Ion bombardment on bottom
 - Passivation removal
 - Etching
- Little ion bombardment on sidewalls
 - No passivation removal
 - Little lateral etching
- **DIRECTIONALITY !!**

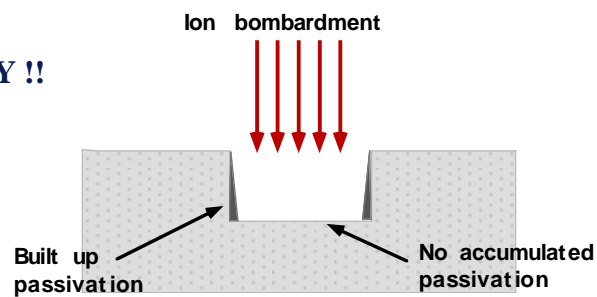

Plasma Etching Tools and Configurations



Dry Etching Tools

- Various tools have been devised to etch materials in plasmas
 - Different physical configurations
 - Different power sources
 - Different gases



Ion Milling

- Plain physical sputtering from an ion beam source
 - Kaufman Ion Source
 - Plasma based
- Typically
 - Ar⁺
 - 500 eV
 - Current 100 mAmp
 - Rate 300-1000 Å/min
- When you don't have a reactive chemical process
 - Magnetic materials
 - Superconductors
 - Hard oxides

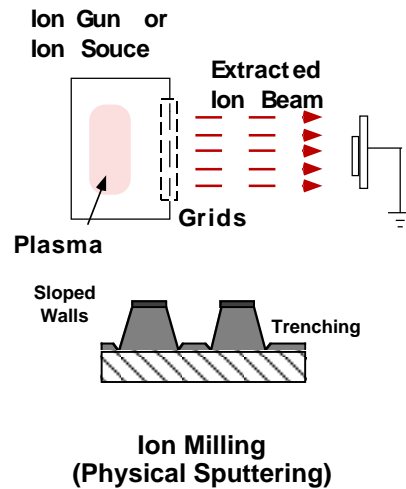

NNIN

CNF NanoCourses



Dry Etch, page 33

CORNELL

Ion Milling at CNF

- Homemade tool
- Wafers up to 3" inch
- Typical rates
 - C 44 Å/min
 - Al 730 Å/min
 - W 380 Å/min
 - Ti 380 Å/min
 - Si 380 Å/min
- Rates fairly uniform across materials
- A purely physical sputtering, momentum transfer technique



NNIN

CNF NanoCourses



Dry Etch, page 34

CORNELL

Generic Plasma Reactor

- Vacuum system
- Controlled pressure
 - Millitorr range
- Controlled flow of gas
- Power
 - RF, DC, μ wave
- Coupling
 - Capacitive
 - Inductive
- Different configurations of geometry, pressure, power, etc., give you different effects, different techniques

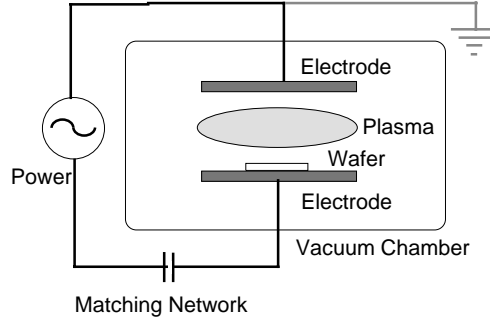

Matching Network (RF)

- RF Power Supply impedance = 50 Ohms
- Plasma Impedance
 - Complex (non-resistive)
 - Not 50 Ohms
- Matching Network required to facilitate power coupling
 - Unmatched impedance = Large Reflected Power
- Variable LC network
 - Autotune to minimize reflected power

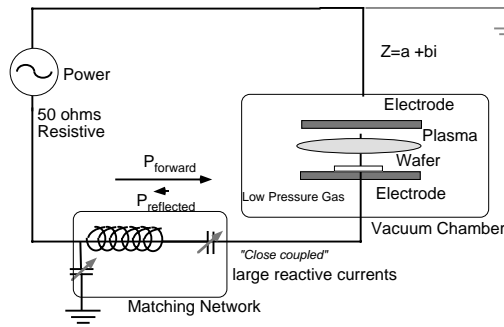

Plasma Etching

- Barrel Reactor
- Wafers immersed in plasma
 - Little ion bombardment
- Generally isotropic
 - Highly “chemical” process
- Plasma Cleaning/ Resist Stripping

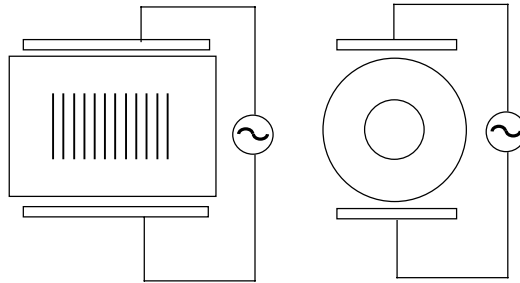

(Low Pressure) Reactive Ion Etching (RIE)

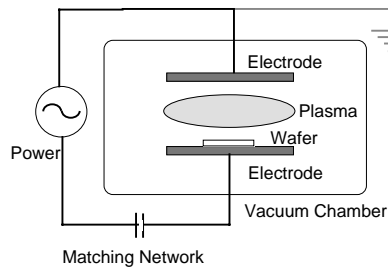

- Etching with reactive ions generated in an RF plasma
- RF Capacitive Diode Configuration
 - 13.56 Mhz
 - 50-200 Watts
 - 5 - 50 mtorr
 - 2-100 sccm gas flow
 - Rates ~ 100 - 1500 Å/min.
- Various gases depending on material to be etched

(Low Pressure) RIE at CNF

- Plasma Therm 72
- Plasma Therm 720
- Homemade Tool

- Both F and Cl chemistries

- Low rate
- High energy bombardment



High Density Plasmas

- Various ways to increase ionization
 - MIE, ECR, ICP, etc
- More electrons =====>
- More ions =====>
- More ion current=====>
 - Lower voltage at same power
 - Lower ion bombardment energy but more ion current
 - More ionization and more reactive radicals
 - Less damage but higher etch rate

RF Plasmas in Magnetic Fields: Magnetron

- Magnetic confinement
- $E \times B \implies$ Increased electron path length before wall loss
- More ionization
- More reactive etch species
- Yields higher etch rates

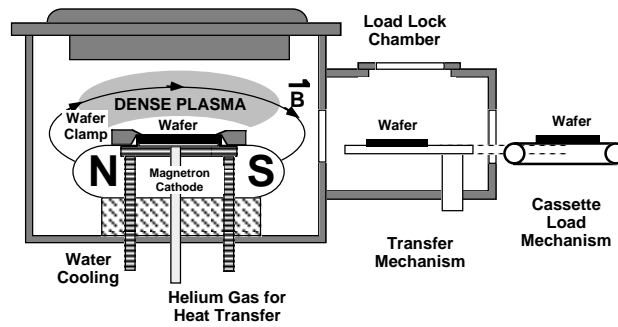

NNIN

GNF NanoCourses



Dry Etch, page 41

CORNELL

MIE at NBTC

- The MIE etches four times faster than our basic RIE tools
- CHF_3
- Predominantly oxide etching
- 3" wafers ONLY !!!!!
- 220 nm/min oxide
- An obsolete technique



NNIN

GNF NanoCourses



Dry Etch, page 42

CORNELL

Electron Cyclotron Resonance RIE (ECR)

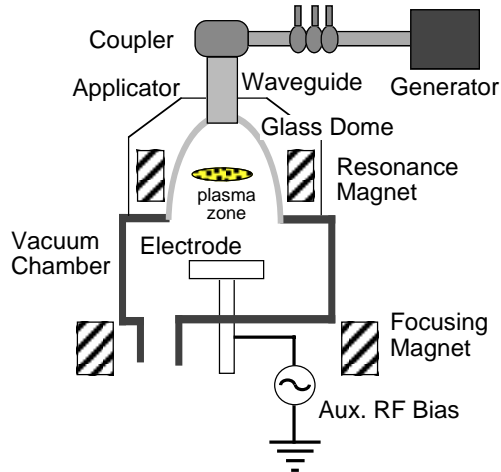

- Excitation tuned to the electron's natural rotational resonance in a magnetic field
 - 2.45 GHz microwaves
 - 875 Gauss
- Power coupled directly into the electron motion
 - More efficient
 - Higher ionization

ECR Etching

- Only a very small region (a flat disk) has the appropriate resonant condition
- All power is adsorbed in small volume
- Ions stream along magnetic field lines
- Additional directionality provided by lower RF bias

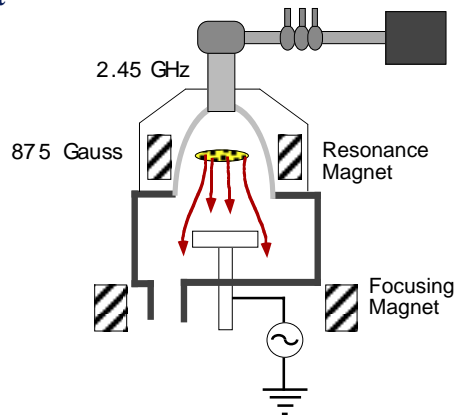

ECR at CNF

- Plasma Quest
- 3" and 4" wafers
- Primarily Chlorine gases
- Primarily GaAs and Silicon



Inductively Coupled Plasmas (ICP)

- Power coupled into plasma inductively
- Separate RF substrate bias
- Ionization separated from the acceleration
- High Density Plasma
 - KiloWatts

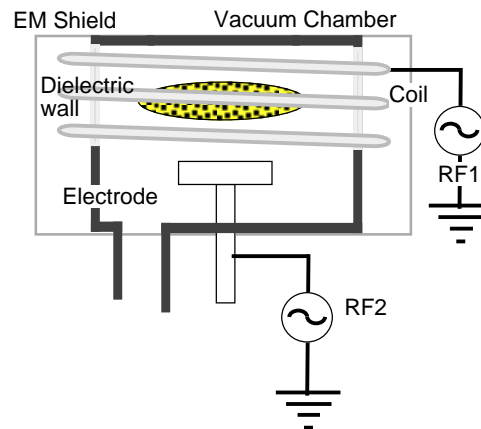

ICP at CNF

- Plasma Therm SLR 770
 - 3 systems/2 processes
 - Chlorine etching of Silicon
 - Deep RIE (Bosch™) (two)
 - Shallow and deep silicon structures
 - 3" and 4" whole Si wafers



Etch Processes and Their Characteristics

Lots of Process Parameters

- Type of instrument/plasma
- Gas mixture
- Gas flow rates
- Pressure
- Power
- Temperature

- Fixed recipes will get you close, but.....



Quantitative Etch Characteristics

- Etch Rate
- Selectivity to mask
 - = Etch rate of mask / Etch rate of material
 - Best if > 1
- Selectivity to substrate
 - = Etch rate of substrate / Etch rate of material
 - Important if you want to “stop” on the substrate
- Uniformity across the wafer



Qualitative Etch Characteristics

- Sidewall and base quality
 - Residue
 - Roughness
- Notching of mask/Undercut
- Directionality/Anisotropy



Commonly Etched Materials

- Many different materials are dry etched using plasmas
- Many Gases
 - CF_4
 - CHF_3
 - SF_6
 - Cl_2
 - BCl_3
 - Oxygen
 - Hydrogen
- Materials commonly etched at CNF
 - Si
 - SiO_2
 - Poly Si
 - Si_3N_4
 - Al
 - W
 - TiW
 - GaAs
 - SiC
 - Resist



Common Masks

- | | |
|-----------------|-------------------------------|
| • Plasma | Mask |
| • CF_4 | Resist, metals |
| • SF_6 | Oxide, nitride, Al, resist |
| • Cl_2 | Oxide, nitride, resist (poor) |
| • O_2 | Inorganic materials |



Choices of Gases: Effects on the Etch Process

- Etchant Gases
 - Provide primary etch species
 - Make a volatile compound
- Additive Gases
 - Modify selectivity
 - Modify directionality
 - Promote/remove passivation
 - Increase/reduce etch species concentration
 - Promote plasma stability



Etch Gases

- Generally halogen containing gas
 - CF_4 , CHF_3 , SF_6 , Cl_2
- Other etch gases we do not use
 - NF_3 , Br_2 , HBr , XeF_2



GNF NanoCourses



Dry Etch, page 55



Halocarbon Naming

- Most halocarbons go by their Dupont trade name
- Freon_{tm} 14, Freon_{tm} 13, Freon_{tm} 23 (Dupont)
 - Halocarbon 14, etc. (other brands)
- Right Digit = Number of F atoms
- Next Digit = One more than the number of H atoms
- 3d digit if used = One less than number of C atoms
- All other atoms are Cl unless otherwise noted
 - Freon 14 = CF_4
 - Freon 23 = CHF_3
 - Freon 12 = CCl_2F_2



GNF NanoCourses



Dry Etch, page 56



Etchant Gases

Etchant

- BCl_3
- $\text{C}_x\text{H}_y\text{F}_z$
- SF_6
- Cl_2
- O_2

Material Etched

Al_2O_3 , GaAs
 SiO_2 , Si_3N_4
Si, Poly Si
Si, Poly Si, SiC, Al, GaAs
Organic material



GNF NanoCourses



Dry Etch, page 57



Additive Gases

- Oxide Removal BCl_3 , SiCl_4
 - Surface native oxide
- Passivators O_2 , $\text{C}_x\text{H}_y\text{F}_z$
 - Protect sidewalls
- Inert Gases Ar
 - Plasma Stability
 - Ion Bombardment
- Plasma Inhibitors O_2 , BCl_3 , $\text{C}_x\text{H}_y\text{F}_z$, H_2
 - Chemically modify plasma species



GNF NanoCourses



Dry Etch, page 58



Inhibiting a CF_4 etch

- Adjusting C,H,O balance by adding small amounts of H_2 and O_2
- Add H
 - Reduces free F
 - Polymer formation increases
- Add O
 - Ties up CF_3 radicals
 - Reduces free F
 - Polymer formation decreases
- Important for control of passivations and directionality



Typical RIE Processes at CNF



Resist Stripping with the PT 72

- Low pressure RIE in Oxygen
- O₂ plasmas break down organic materials
 - Typical pressure
 - Typical flow
- Resist etch rates are about 0.1 μm/min
- The addition of a small percentage of CF₄ to the plasma for the first two minutes of the etch can help remove a burned polymer layer produced in fluorine based plasmas



Resist Stripping with the Branson

- P2000 Plasma Asher
 - Plasma etching tool
- Oxygen
- 0.1 μm/min
- 1000 Watts
- Resist strip and descum
- Not after halogen plasma



SiO₂ Etch

- CF₄ and CHF₃ plasmas are best suited for oxide etching
- The addition of H₂ to CF₄ plasmas reduces the number of fluorine radicals in the chamber
 - Increases passivation
 - Increases selectivity to silicon
- Etch rates in the MIE are greater than 200 nm/min
- Etch rates in our RIE systems vary from 30 to 60 nm/min

Cl₂ Etching Process for Si - Anisotropic

- Cl₂ etches silicon
- Cl₂ doesn't etch silicon dioxide
 - Oxide makes a good mask
- Must remove surface oxide
- Multistep process
 - Step 1: Dehydrogenate w/ H₂ at low power
 - Step 2: Native oxide etch with BCl₃
 - Step 3: Etch with Cl₂ using BCl₃, H₂ additives
- Rates as high as 0.35 μm/min

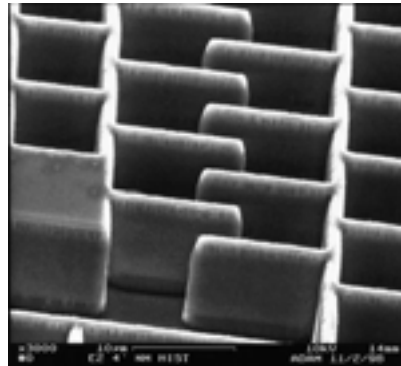

Isotropic Si Etching w/SF₆

- SF₆ with very little O₂ or Ar for stability
- ICP 770
 - 0.2 μm/min
- PT 72
 - 0.1 μm/min

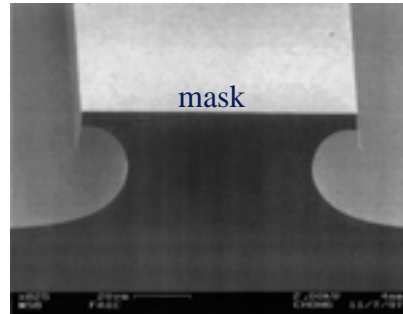

MacDonald Group

Bosch Etching - Deep RIE

- Isotropic fluorine etch driven into anisotropy by a cyclic process deposition/etch process
- Etch rates from 1.6 to 2 μm/min
- Vertical
- Shaped profiles possible

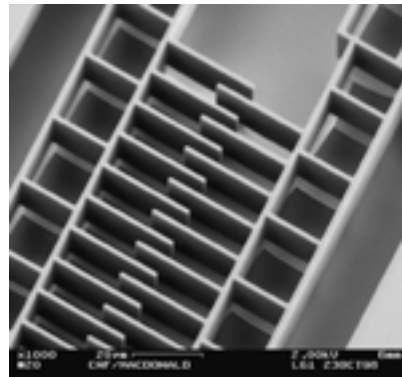

MacDonald Group

Bosch Process, Continued

- Aspect ratios as high as 40:1 can be achieved with some process development
- 50 μm diameter via holes through 3" wafers can be etched in nearly 4 hrs
- Silicon only

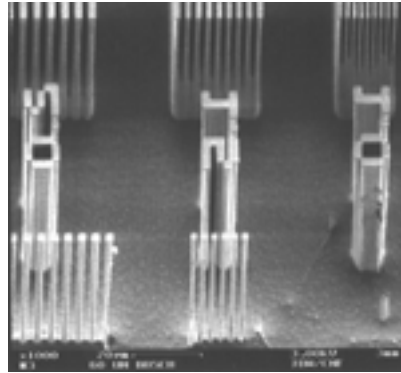

Al Reactive Ion Etching

- PT 720
- Cl_2 etch process
- BCl_3 for oxide removal
- H_2 assists in sidewall passivation for directionality
- Resist mask typically used
- Significant lateral etching when you hit the silicon substrate

Artifacts and Effects



Pressure/Energy Considerations

- General rules to follow
 - Increasing Pressure:
 - Reduces sputtering, and promotes isotropy
 - Decreasing Power:
 - Reduces sputtering, increases Isotropy
 - Decreasing Power:
 - Also reduces etch rate

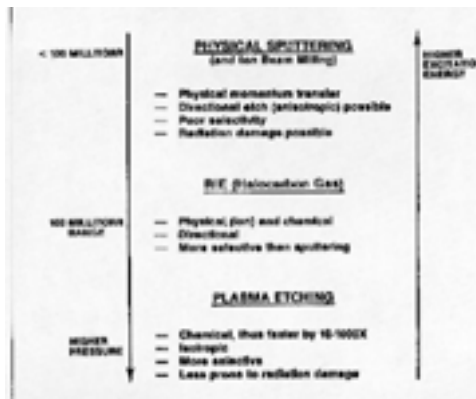

Temperature Control

- Lots of power into wafer
- “Wafer temperature” is important
 - Chemical reaction
- Wafer temperature is generally unknown and difficult to control or measure
- Extremely poor heat conductivity **TO THE WAFER** in vacuum
- Small problem with low powers (100 W)
- **BIG PROBLEM** with high powers (1000 W)

Heat Transfer in Vacuum

- What happens to energy put into wafer?
- Poor heat transfer out of wafer in vacuum
- Few point contacts
- Applies to all vacuum processes
- Easy to get 100°C temperature difference even if you are actively cooling the electrode ! ! ! !
- Easily melt resist

Exaggerated view of wafer-electrode interface

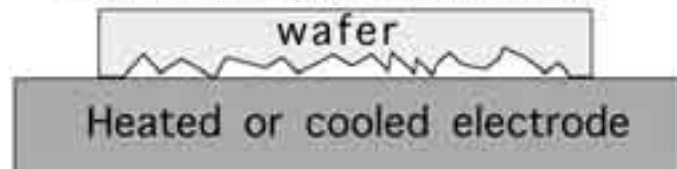

Backside He Heat Transfer

- Bleed small amount of inert gas (He) into cavity behind wafer (1^{-10} torr).
- Molecular heat transfer medium
 - (mfp > wafer gap)
- Many, many bounces each carrying small amount of energy
- Wafer clamp
- Used on all high power etch and deposition systems

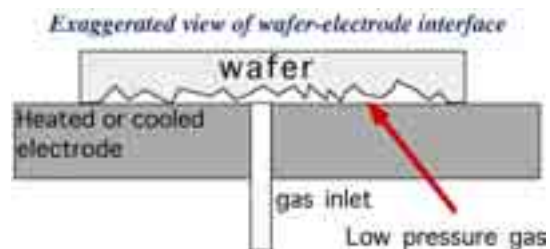

NNIN

GNF NanoCourses



Dry Etch, page 73

CORNELL

“Loading” -- Various Kinds

- Process variation due to variations in amount of material
 - Chemical supply effects
- Many wafers may not etch the same as one wafer
- Inside of the wafer may not etch the same as the outside
- Small features may not etch the same rate as big features
- Etch rate not constant as you go VERY deep
- Dense patterns not same as sparse patterns

- Diffusion of reactants and reaction products
- Consumption of reactants
 - A classical chemical engineering problem

NNIN

GNF NanoCourses



Dry Etch, page 74

CORNELL

Loading Examples

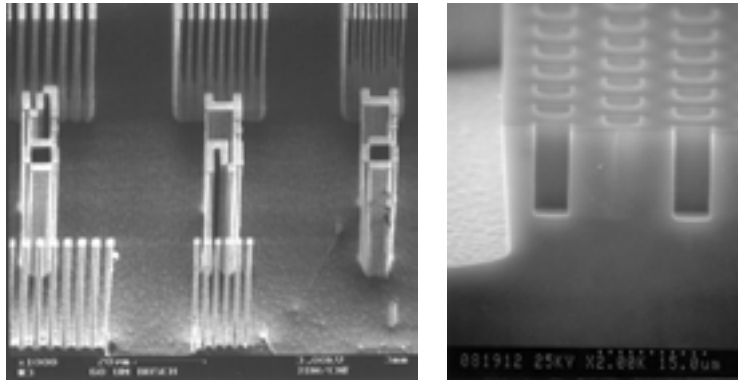

“Grass”

- “Black Silicon”
- Wafer looks black to the eye
- Very rough “spikes” in etched area in SEM picture
- Micromasking by sputtered, non-etching contamination
 - Mask
 - Electrode or chamber
- Either a process problem or a system malfunction
 - Excessive ion bombardment of non-etchable stuff
- Ugly -- VERY BAD

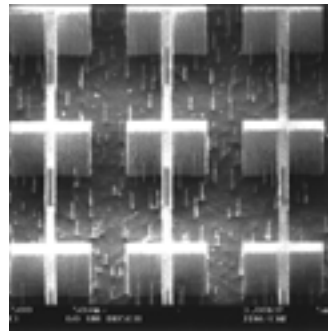

Grass - Micromasking

Rather than

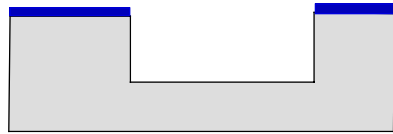

You get

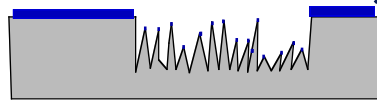

because

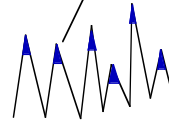
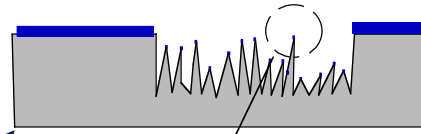

Micromask may come from sample or from chamber walls

NNIN

GNF NanoCourses



Dry Etch, page 77

CORNELL

Residue

- Polymer residue from etch gases
- Polymeric residue from resists
- Redeposited etch materials
- Mixture of all

- Very difficult to remove in standard solvents
- Some very aggressive solvent mixtures available

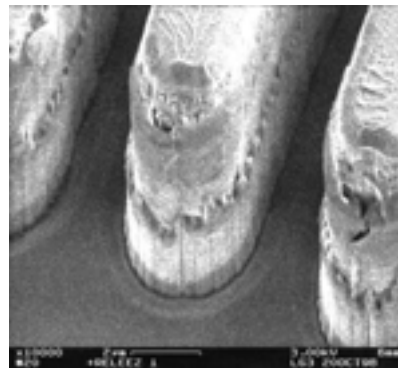

NNIN

GNF NanoCourses



Dry Etch, page 78

CORNELL

Undercut

- Excessive lateral etching
- Loss of dimensional control

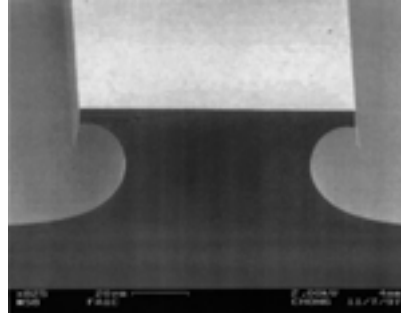

NNIN

GNF NanoCourses



Dry Etch, page 79

CORNELL

Base Notching / Sidewall Taper / Faceting

- A signature of excessive ion bombardment
 - Too much bias voltage
 - Not enough “chemistry”

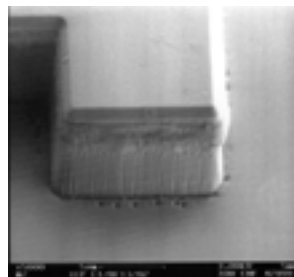
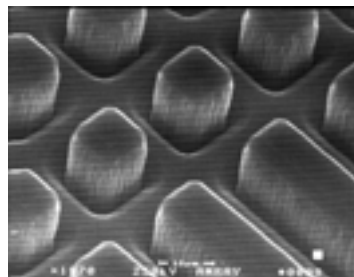

NNIN

GNF NanoCourses



Dry Etch, page 80

CORNELL

Resist Wear Out

- Edges
- Plane

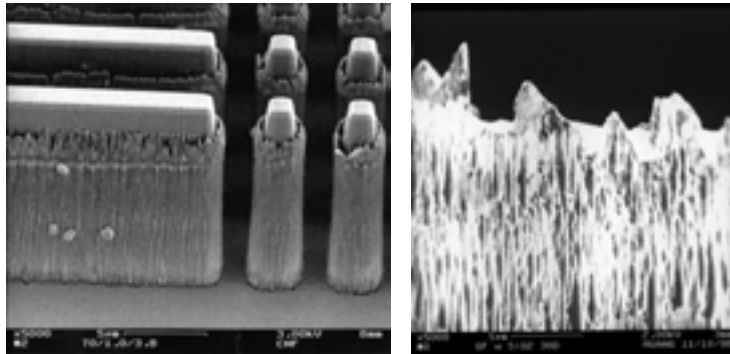

NNIN

GNF NanoCourses



Dry Etch, page 81

CORNELL

Summary

- “Plasma Etching” (broad sense) is one of the most heavily used techniques in CNF
- At least 11 tools available
- Many variables and parameters effect results
- Processes transfer poorly from one tool to the next
- What is best for someone else may not be best for you

- There is SCIENCE involved
 - Try to understand the recipes and the results

NNIN

GNF NanoCourses



Dry Etch, page 82

CORNELL

NanoCourses 2004, Part 3

Practical Thin Film Technology

The Flatland of Thin Films
Puttin' 'em on and Takin' 'em off

Sputtering
by
Jerry Drumheller

Presented by the
CNF Technical Staff
for the education of CNF Users,
Potential Users, and Industrial Sponsors

NNIN

CNF NanoCourses



Sputtering, page 1

CORNELL

CVC Sputtering System at CNF



NNIN

CNF NanoCourses



Sputtering, page 2

CORNELL

Thin Film Deposition by Sputtering

What is Sputtering?

- Ejection of atoms from a solid surface by energetic atomic particles
- An ion impact (fast atom) phenomena
- Primarily a momentum transfer process

It is Universal to all Ion Impacts:

- Used to remove material in a controlled fashion
 - Ion milling
 - Depth profiling
- Undesirable effect in ion implantation
- Usually used to transport material from one surface to another
- Thin film deposition



Ion Impact Phenomena

- Sputtering is a momentum transfer process
- Energy is transferred to many surface/bulk atoms
 - (Not simple 1 on 1 billiard ball collisions)
- Atoms ejected with energies of < 10 eV
- Mixing
- Threshold for sputtering -- tens of eV
- Clusters
- Yield (> 0.5 to 5 atoms per ion)
 - Function of angle, energy, mass of ions and target atoms



Ion Impact

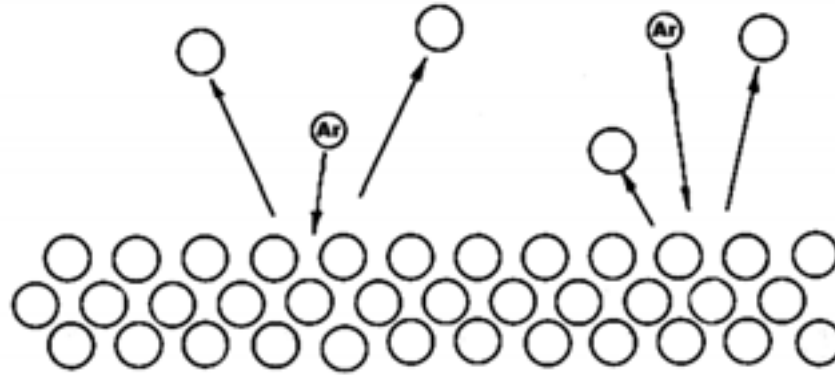

Sputter Deposition

- **Caution:**
 - More often than not, the term sputtering is used to refer to sputter deposition!
- **Ion impact is used to transfer material from:**
 - Source (target) (the pure material), to Substrate (sample)

Target & Sample

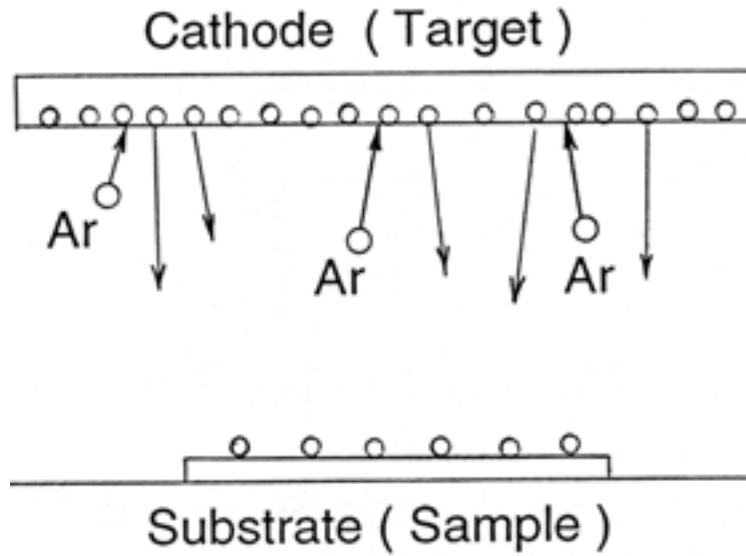

Why?

- **Non-Thermal;**
 - Ability to do other materials
- **Extended Source;**
 - Step coverage, Large areas
- **Alloys;**
 - What you have is what you get
- **Compounds;**
 - Reactive sputtering

Where is Sputtering (Sputter Deposition) Used?

- Architectural glass
- Barrier layers
- Car bumpers
- Decorative Coatings
- Electronics
- Optics
- Plastics
- Protective Coatings
- Wear Coatings



Ways To Do Sputter Deposition

- Ions from an Ion Beam (directed at Target):
 - More versatile, research
- Ions from a Plasma:
 - More common and practical



Glow Discharge Sputtering

First of all: What is a Plasma?

- An ionized gas
 - In our case, it is a low pressure gas with both positive and negative charges as well as energetic neutrals
- Plasmas generated by DC and/or RF glow discharges are widely used in thin film processing as a source of ions
- RF, Low Frequency (audio range), and Microwave
- Usually parallel plate capacitor, but other configurations are used, such as cylindrical
- Vacuum, low pressure controlled atmosphere used

Glow Discharge Sputtering System

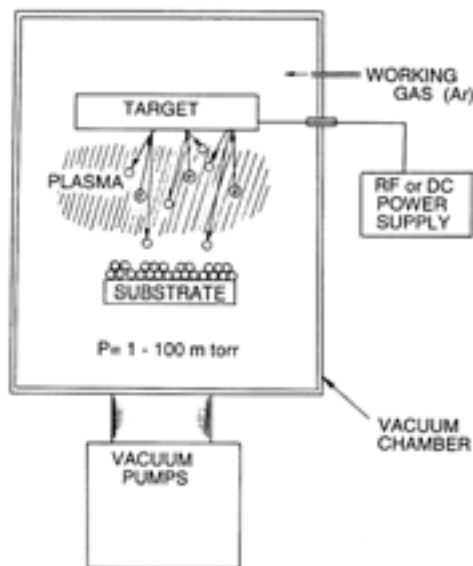

DC Glow Discharge

- High voltage DC across a low pressure gas
- Ionization
- Electrons accelerated
- Cause more ionization, etc
- These plasma characteristics also apply to Plasma Etching

Abnormal Glow

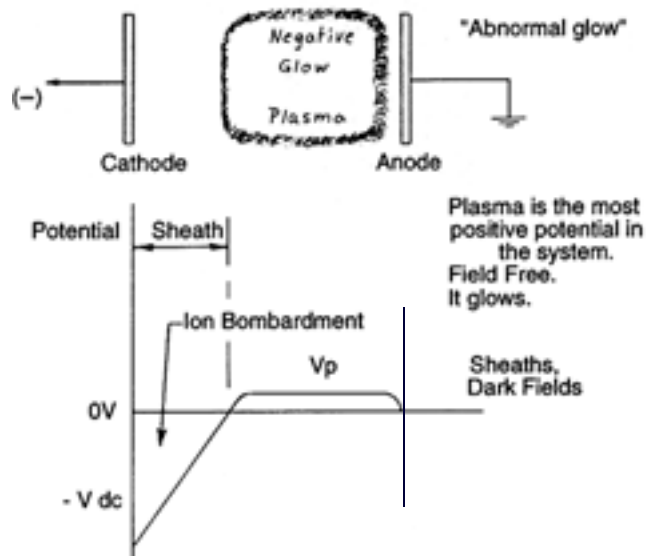

DC Diode

Anode = Chamber Walls
Cathode = Target

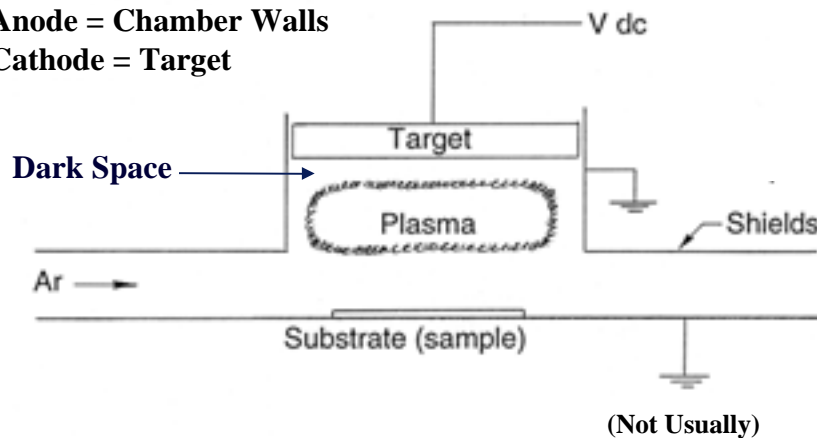

Operating Characteristics:

- Pressure: 20 - 50 mtorr
- V: 2000 - 3000 volts
- I: Hundreds of milliamps (up to 1 amp)
- Power: Kilowatts
- A HOT process -- lots of sample bombardment
- Sample and Target must be conductors
- Not widely used anymore
- AC DISCHARGE
- As we go to low frequency AC, ions and electrons follow the field and it acts like a varying DC discharge

However:

- At > 50 kHz ions can't keep up
- Electrons gain energy from the RF field and cause more ionization
- Plasma is easier to maintain
- Less bombardment of substrates
- Electrodes do not have to be conductors

RF Glow Discharge

- Typically 13.56 MHz
- Reasonably common
- Average field is similar to DC discharge

RF Plasma

- What kind of load is a plasma?
- Partially Resistive:
conduction through sheaths
- Partially Capacitive

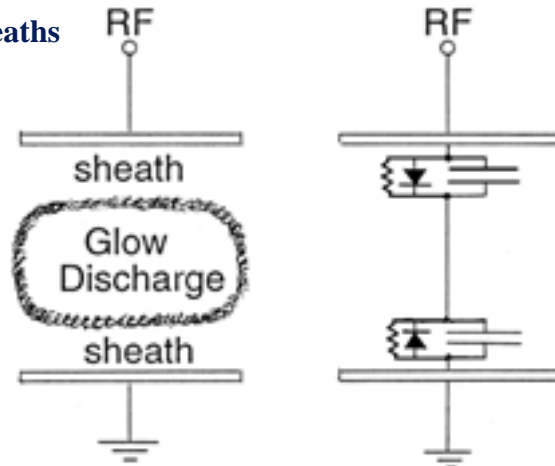

How?

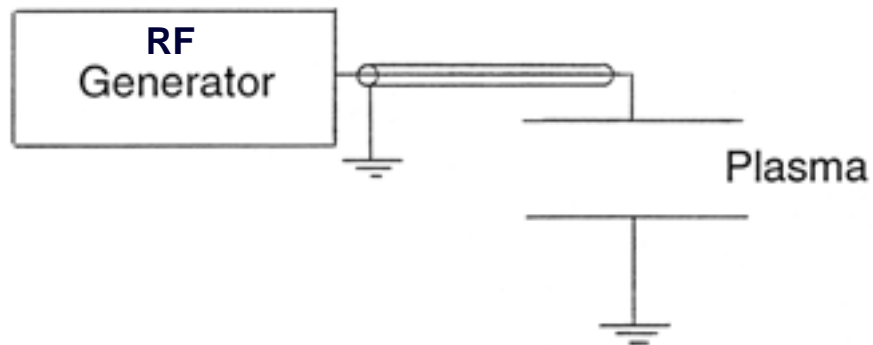

How do we deliver power to such a load?

Matching Network.

RF Matching Network

- A device set up as a variable series/parallel load used to match the impedance of the generator to the impedance of the load
- Maximize Transmitted (applied) power
- Minimize Reflected power
- Keep the power supply happy
- Generator has $Z_{out} = 50\Omega$ resistive
- Plasma has $Z_{out} \neq 50\Omega$ resistive and capacitive
- We must make the generator see net 50 ohms impedance

RF Generator

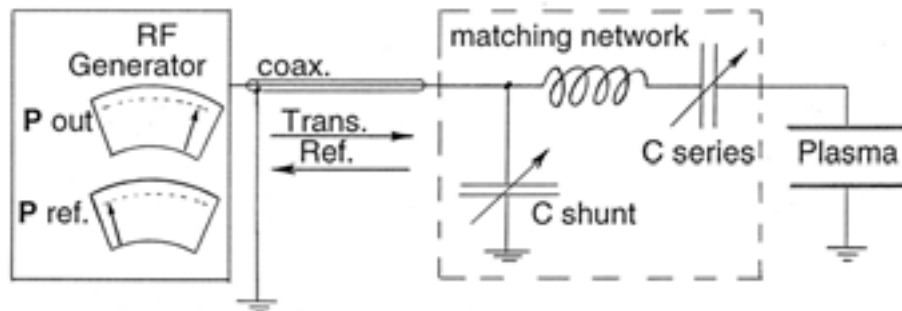

Manually tune for minimum reflected power
or
Auto tune, using feedback and detected phase shifts

CVC Sputter Coater, Open For Loading



NNIN

GNF NanoCourses



Sputtering, page 23

CORNELL

All That Was Plasmas in General

- How do we use plasmas to do glow discharge sputtering?
- DC Diode or RF Diode

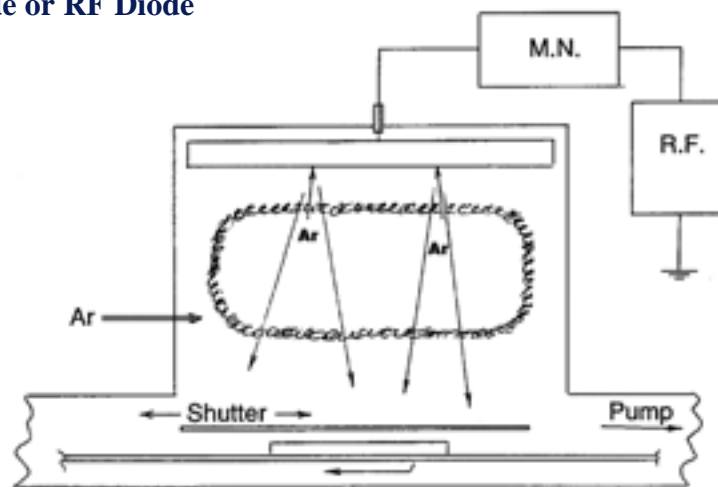

NNIN

GNF NanoCourses



Sputtering, page 24

CORNELL

Magnetron Glow Discharge

- Third type of plasma
- We need faster deposition (more throughput) *So,*
- We want DENSER plasma, more ion bombardment
 - We can't arbitrarily increase pressure
 - We need to get more ionization per electron
- Confine the electrons (Plasma) magnetically
- Result:
 - More ionization; electrons spiral, longer path
 - Lower impedance plasma, more current, less voltage
 - Electrons are trapped, away from the anode surfaces
- Usually very non-uniform sputtering due to magnetic field
- We have to find ways to correct or compensate for this



Planar Target Assembly

- Usually seals in to become part of vacuum wall
- Water cooled backing plate
- Non-uniform deposition with magnetron--substrate motion and shields used to improve uniformity



Disk Cathode Bar Magnet Arrangements

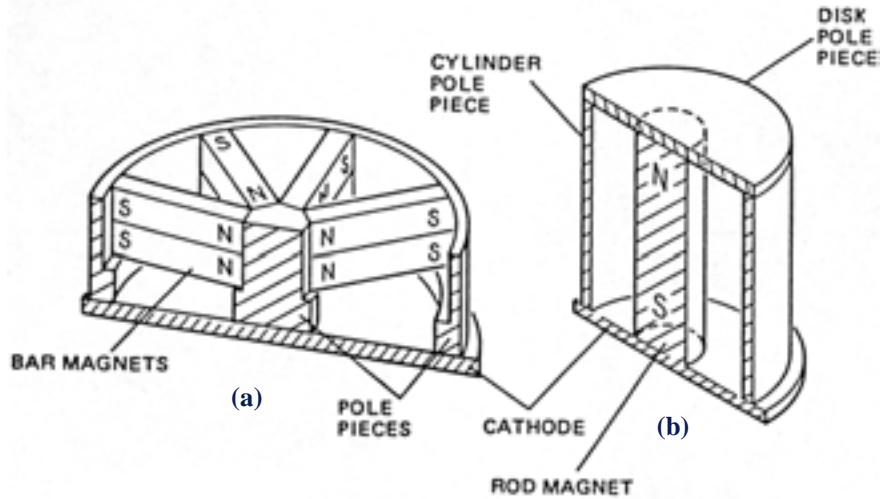

Disk cathode bar magnet arrangements; (a) radial magnets (b) central rod magnet

Planar Magnetron Sputtering

- DC Planar Magnetron
- RF Planar Magnetron
 - Circular or Rectangular

Magnetron Target
Sputter Distribution

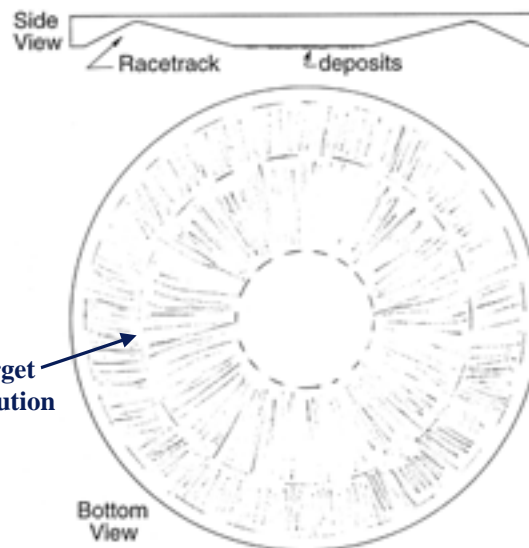

Used Target



NNIN

GNF NanoCourses



Sputtering, page 29

CORNELL

Shields to Correct for Coating Non-Uniformity

Shield used to give uniform coating thickness

- Located as close as possible to substrates

Sputter Target

“Racetrack” = Ring of greatest sputter removal rate

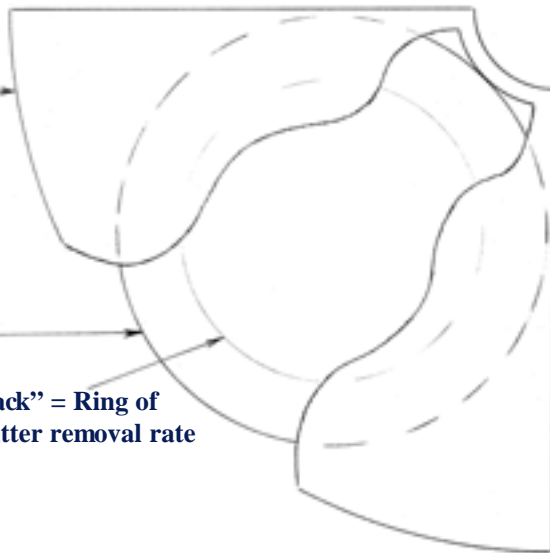

NNIN

GNF NanoCourses



Sputtering, page 30

CORNELL

Sputter Shield



Planar Target Assembly

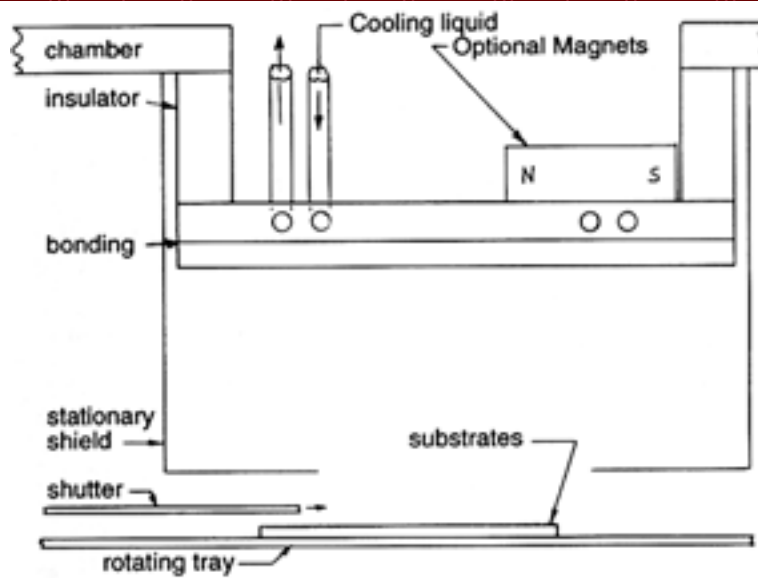

Three Targets & Ion Beam



Sputtering Targets

- **Target Bonding:**
 - Epoxy bonding
 - Metallic Bonding
 - Targets:
 - 99 % to 99.99999 % Purity
 - Vacuum cast
 - Pressed powder
- **Our system has 8 inch diameter, 1/4 inch thick disks**
- **Cost:**
 - Backing Plate -- \$3000
 - Bonding --\$ 400
 - Target -- \$500 - \$2500 (These are not precious metals)
 - \$4000 - \$6000 for each new material

A Typical Sputtering System

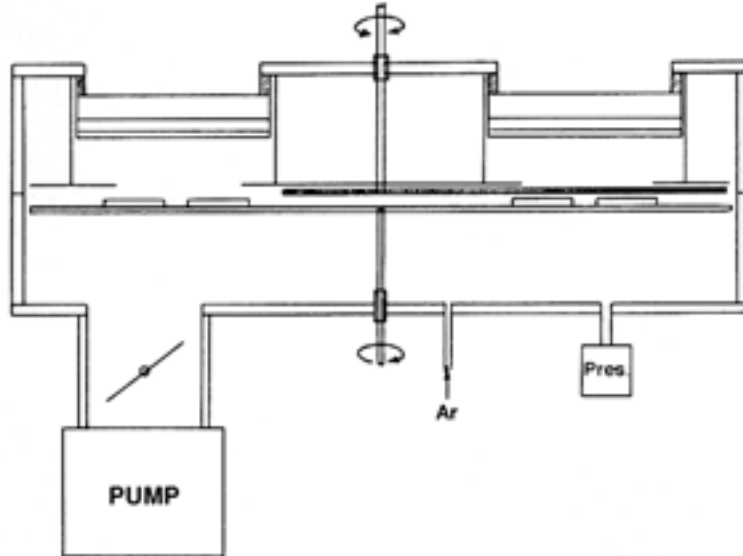

NNIN

GNF NanoCourses



Sputtering, page 35

CORNELL

Rotating Substrate Carrier



NNIN

GNF NanoCourses



Sputtering, page 36

CORNELL

Sputter Deposition Processing

Some Terms:

- **Presputtering:** Plasma is used to sputter clean the target surface before coating, by running the plasma with the shutter closed
When is it clean?? Watch the voltage!
- **Backsputtering:** Use applied bias to generate a plasma between the sample and other shields, thus attracting ions to the samples to “sputter clean” them before deposition (Can cause redistribution of dirt)
- **Ion Beam Cleaning:** Using a dedicated internal ion beam source for in-situ substrate cleaning
- **Bias Sputtering:** Sputtering with negative substrate bias applied
Can modify film structure and composition



GNF NanoCourses



Sputtering, page 37



Substrate Bias

- We can apply a negative voltage to the substrate
 - RF or DC
 - Direct or capacitively coupled
- Positive bias will increase the anode sheath voltage
 - Usually avoided



GNF NanoCourses



Sputtering, page 38



Bias Sputtering

- Use negative substrate bias during sputtering
 - Enhanced ion bombardment of samples
- Why??
- Direct energy to substrate to:
 - Modify film growth
 - Change crystal structure, grain structure
 - Sputter off loose impurities, improve film properties
 - Resputter to alter composition, step coverage, etc
 - Modify stress
- Also:
 - Heats substrates
 - Damage
 - Stress

No Substrate Bias

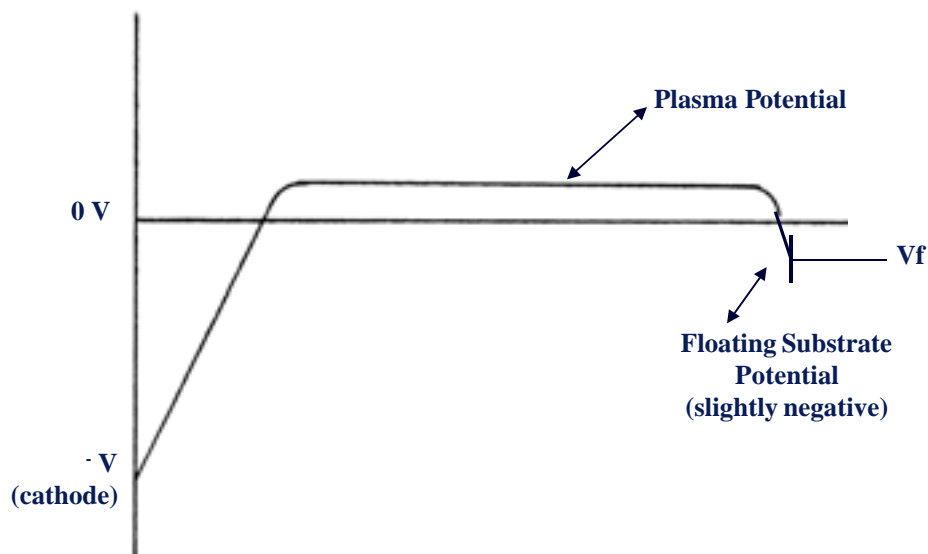

Positive Bias on the Substrates

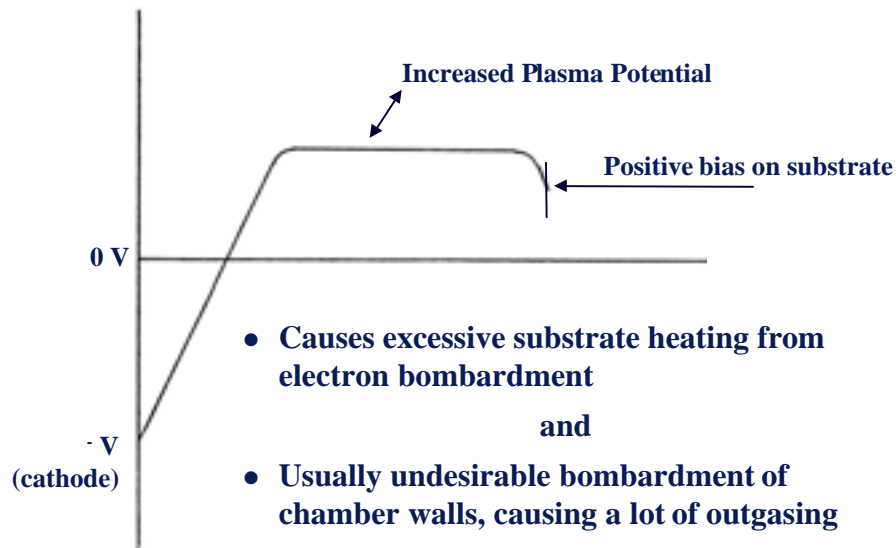

Ion Beam for Substrate Cleaning or Film Modification

- Sputter off the top atom layers of the substrates
- Can harden films or change composition

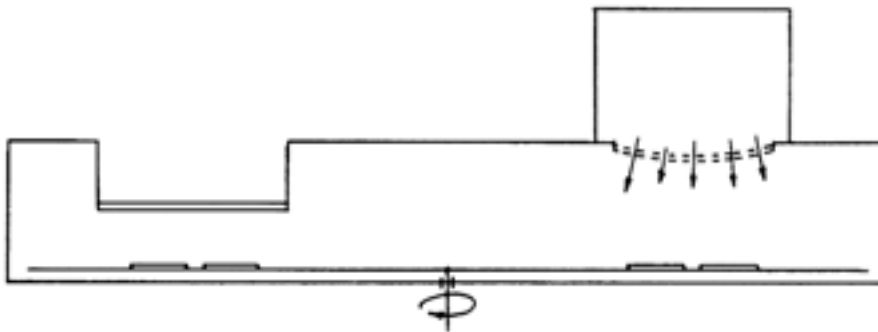

Process Sequence

Typical Deposition Sequence:

- ❖ Vent Chamber
- ❖ Load substrates, and evacuate to required base pressure
- ❖ Set up Argon flow and pressure
- ❖ Back sputter, or ion beam clean substrates
- ❖ Turn on sputter power supply
- ❖ Pre-sputter to clean target
- ❖ Open shutter
- ❖ Deposit on sample for given time
- ❖ Shut off power or close shutter
- ❖ Vent, remove substrates
- ❖ Evacuate chamber



GNF NanoCourses



Sputtering, page 43



Reactive Sputtering

- What if we want to make an oxide or nitride?
- Sputtering a compound target may not give you what you want!
- We can sputter in reactive gas
- e.g.
 - $\text{Ti} + (\text{Ar}, \text{N}_2) \text{ -----> TiN}_x$
 - $\text{Si} + (\text{Ar}, \text{O}_2) \text{ -----> SiO}_x$
 - $\text{SiO}_2 + (\text{Ar}, \text{O}_2) \text{ -----> SiO}_x$
- **Problem:** Compound control
- **Question:** Is the compound synthesized at the target or at the substrate?
- **Answer:** Both or either! (Depends primarily on the gas partial pressures used. This determines sputter rate vs. reaction rate.)



GNF NanoCourses



Sputtering, page 44



Reactive Sputtering

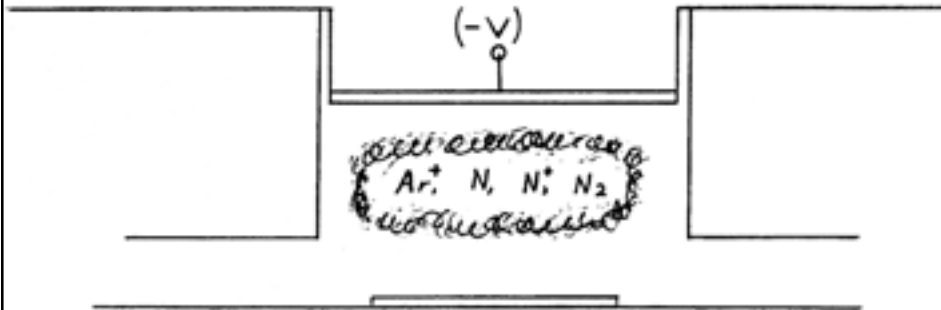

Case 1: (Slow Deposition)

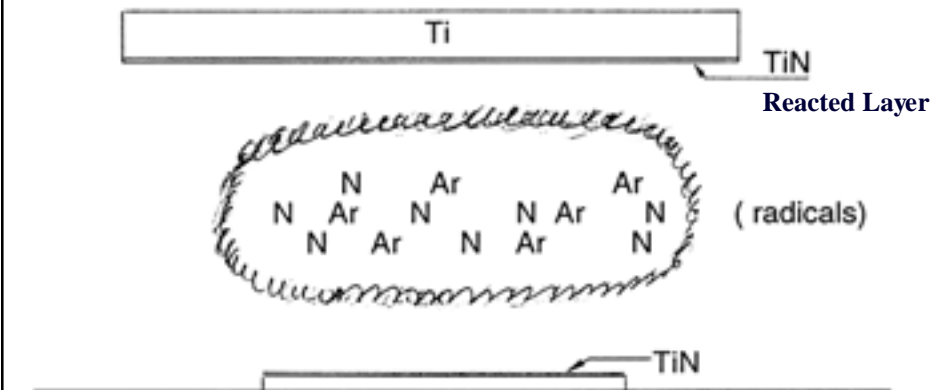

Case 2: (Faster Deposition)

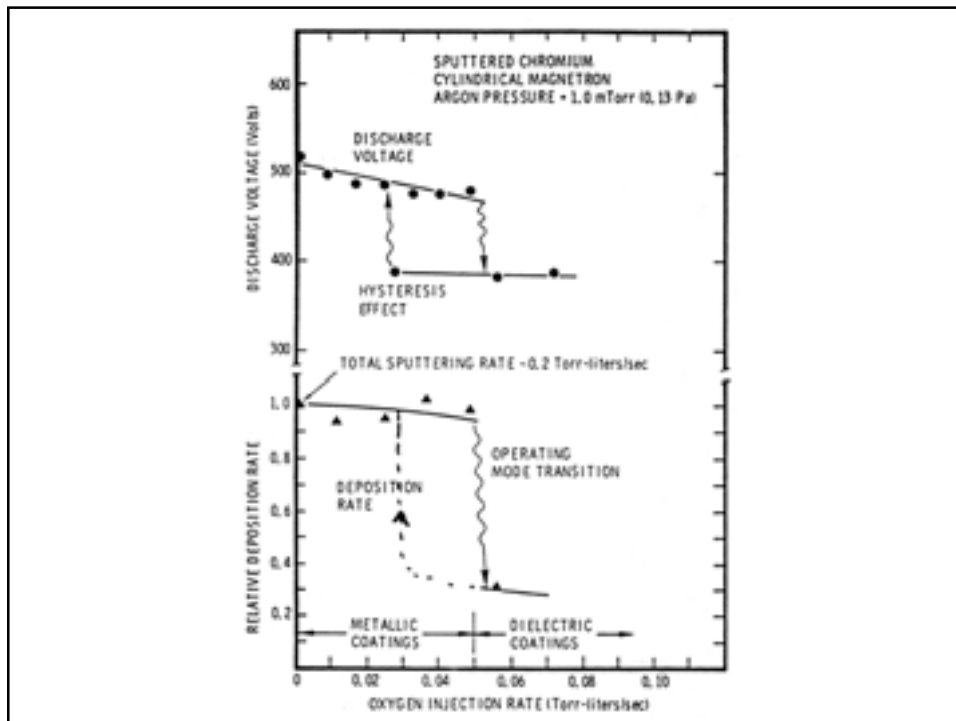
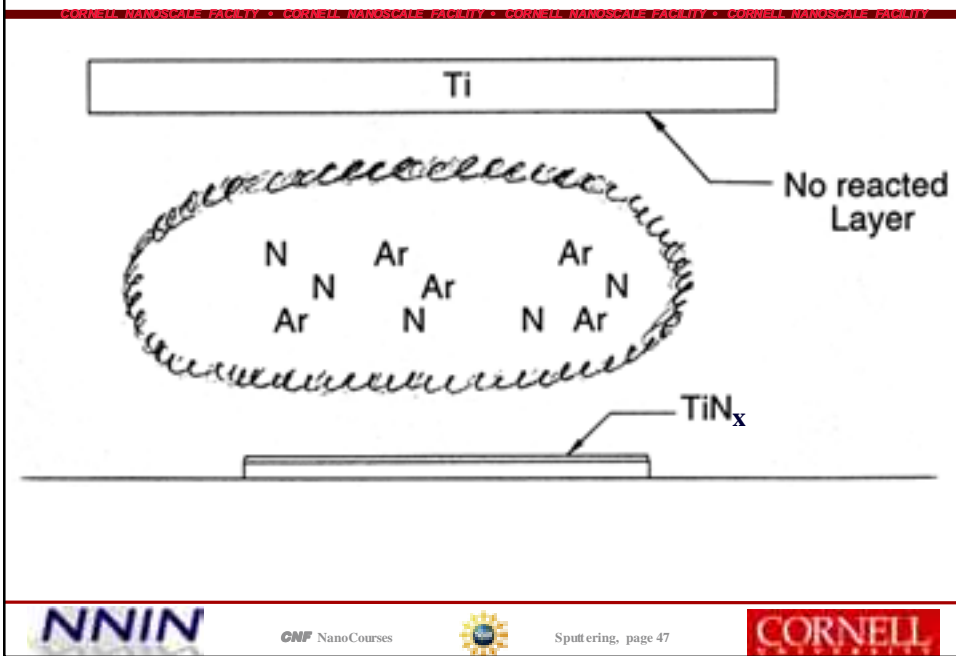

Sputtering of Alloys and Compounds

- At steady state, material released from the target surface has to equal the composition of the target
- For many alloys and compounds, the deposited film will also equal the target composition
- Qualifications:
 - No diffusion in target
 - Anisotropic
- This makes it relatively easy to sputter alloys and get the desired composition
- (Unlike evaporation)

Different Yields and the Altered Layer

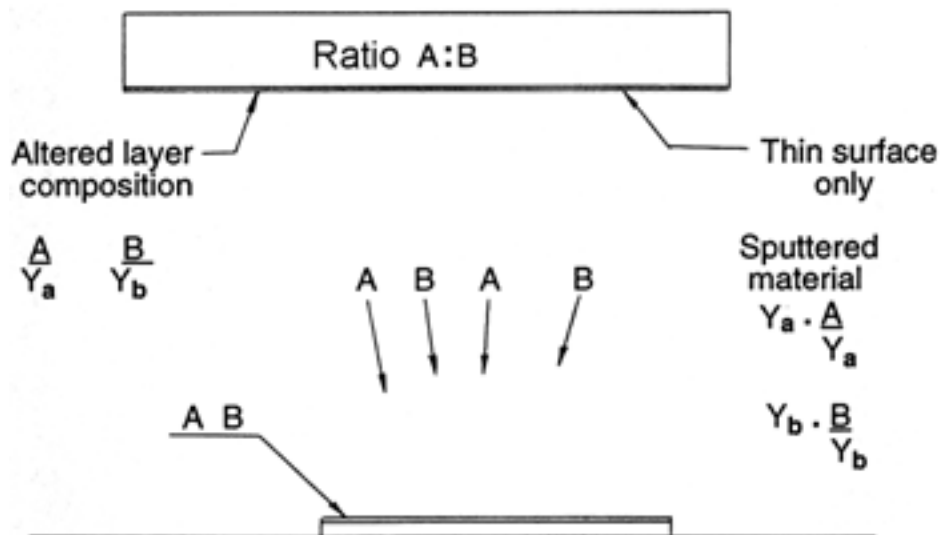

Heat Load

- Only 1% of applied power goes into sputtered atoms
- 75% goes into target heating
- 24% goes into substrate heating, electrons, ions, neutrals
- Substrates are basically thermally isolated in most cases
- Rate of heat rise; can be significant, especially in longer depositions

Stress

- Thin films can be highly stressed (All modes of deposition)
- Film may want to contract or expand with respect to the substrate

Compressive

Film wants to expand.

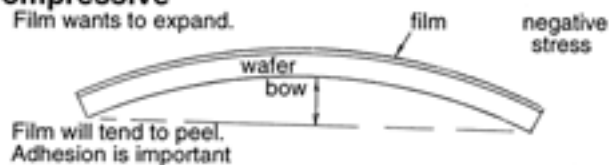

Tensile

Film wants to contract



Film will tend to crack or haze.

Effects of Stress

- "Soft" materials will deform to accommodate stress (hillocks)
- NOT an insignificant effect
- Can bend (bow) a 3" wafer 50 μm in the middle
- Can cause peeling, cracking, etc
- Defects, also electrical



Sources of Stress

- Two primary sources:
 - Thermal
 - α Thermal expansion
 - α substrate \neq α film
 - $T_{\text{dep}} \neq T_{\text{room}}$
 - Intrinsic:
 - Due to non-equilibrium structure
 - Not grown at equilibrium
 - Bonds are not relaxed, etc
 - *Greatest source of stress in sputtered films*
- Evaporated Films:
 - Stress not very significant, usually
 - Most are slightly tensile
- CVD: Some thermal stress
- Sputtering:
 - Lots of stress, tensile or compressive, mostly intrinsic



How to Measure Stress

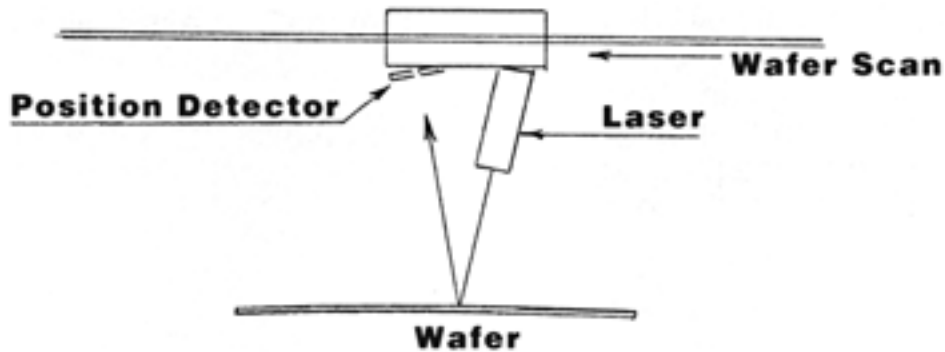

Controlling Stress

- Energetic particle bombardment induces....
- Compressive stress
- Pressure effect:
 - Bombardment by fast neutrals
 - Atomic peening
 - Non-equilibrium atomic spacing
- As p increases, less neutral bombardment, more tensile film
- As p decreases, more neutral bombardment, more compressive film
- Can be very pressure sensitive, ± 1 mtorr

Pressure Graph

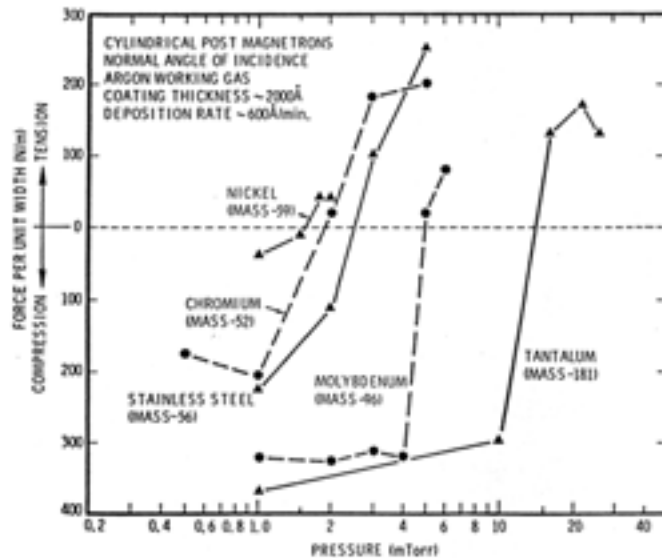

Gas Incorporation

- Films may have up to 10% incorporated gas
- Substrate bias:
 - Gas content increases with increasing bias
 - More bombardment
 - Implantation of ions
- Target - voltage / power:
 - Gas content increases with target voltage, implantation of neutrals
- Substrate temperature:
 - Gas content decreases with increasing substrate temperature
- Pressure:
 - Gas content increases with decreasing pressure
 - (Lower pressure, more ion / neutral bombardment)

Step Coverage

- Unbroken, uniform coverage over non planar substrates
- In sputtering we have:
 - Large area source
 - Randomized arrival directions (high P)
- Step coverage is (can be) better in sputtering than in evaporation
- This can be desirable, or undesirable, depending on what you want to do

Step Coverage Diagram

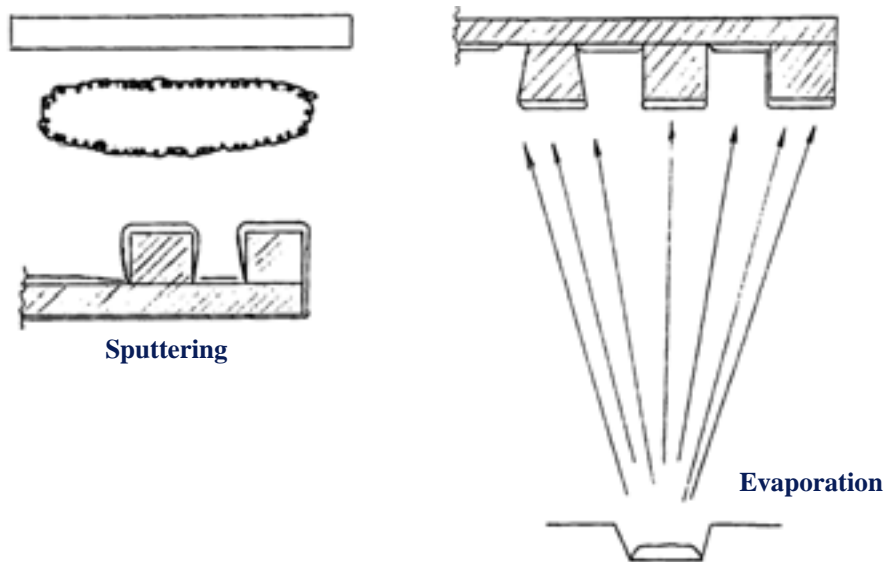

Grain Structure

- Film growth (particularly in sputtering) is a non-equilibrium process
- Grain size / type is determined by mobility of nucleating atoms on surface
- Mobility is a function of:
 - Substrate temperature
 - Diffusion (related to melting temperature, roughly)
 - Extra energy inserted by ion / neutral bombardment
 - Substrate - adsorbate bonding

The 'Famous' Diagram (After Thornton)

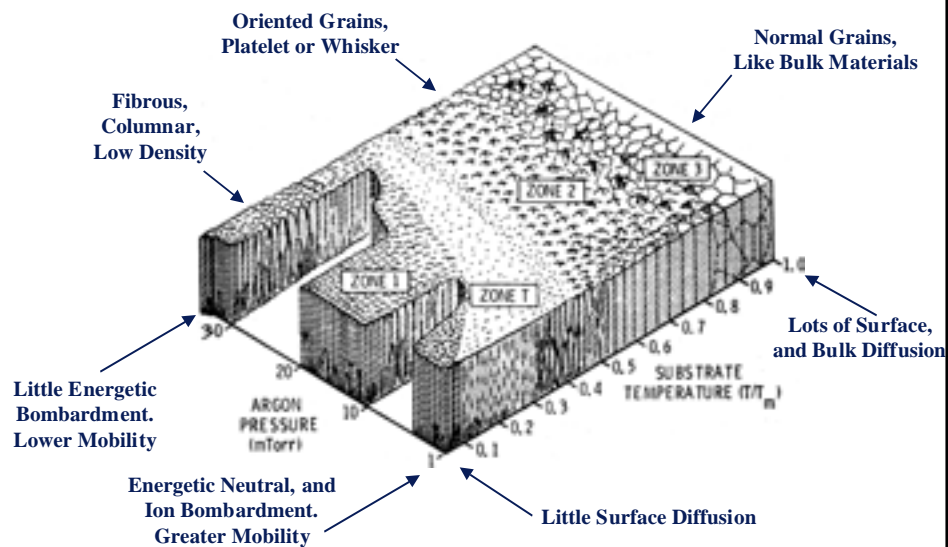

Some Characteristics of Sputtered Deposition

- No spitting from source as in evaporation (can have arcing)
- Process is similar for most materials
- Can sputter high melting point materials easily
- Large area targets:
 - Easier to get uniformity over large areas, high volume production
- Can sputter alloys / compounds without undue fractionation
- In situ cleaning with ions
- Step coverage
- May or may not have less heat load
- Differences in grain structure, adhesion, impurities
- Lift off usually difficult to impossible due to:
 - Heating resist, sidewall coverage



GNF NanoCourses



Sputtering, page 63



Evaporation

- Sputtering is much more widely used in production than evaporation
- Evaporation is sometimes easier and preferable in a lab

However...

- Different, but not necessarily better



GNF NanoCourses



Sputtering, page 64



Commonly Sputtered Materials

- **Al and Al alloys for IC metallizations:**
 - Al + 4% Cu
 - Al + 1% Si
 - Al + 4% Cu + 1% Si
- **TiW Barrier layer 10% Ti (atomic) 90% tungsten**
- **We have:**
 - Al, Al alloys, Co, Cr, Cu, MgO, MoSi₂, Nb, Si, SiO₂, Ta, Ti, TiW, W
- **Conductors:**
 - Magnetic materials
 - Compact disks
 - Optical materials



Summary



NanoCourses 2004, Section 3

Practical Thin Film Technology

The Flatland of Thin Films
Puttin' 'em on and Takin' 'em off

Chemical Mechanical Polishing (CMP)

by
Dan Woodie

Presented by the
CNF Technical Staff
for the education of CNF Users,
Potential Users, and Industrial Sponsors



CNF NanoCourses



CMP, page 1



Chemical Mechanical Polishing

- Developed by IBM in the late '80s
- Originally called Chemical Mechanical Planarization (CMP)
- Utilized to planarize (flatten) step heights in IC wafers
- Currently, CMP is a high growth area in the IC industry utilized for all advanced (0.35 μm and below) devices
- Innovative idea when first applied by IBM
 - Spend billions on equipment to keep wafers clean and particle free
 - Make sure all processing equipment does not touch 'pristine' surface of wafer
 - Put wafer in polishing tool and rub abrasive across the surface



CNF NanoCourses



CMP, page 2



Why Planarize?

- Step heights are created when patterning wafers with thin films
- Can affect further processing steps

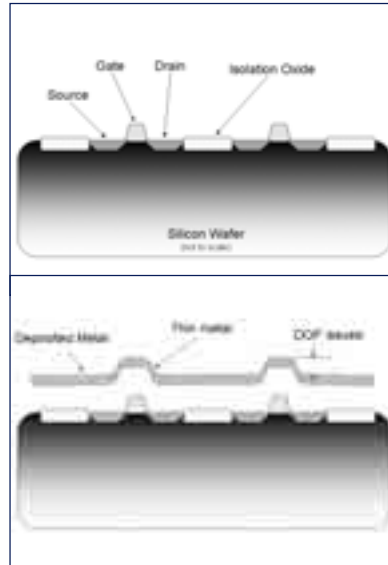
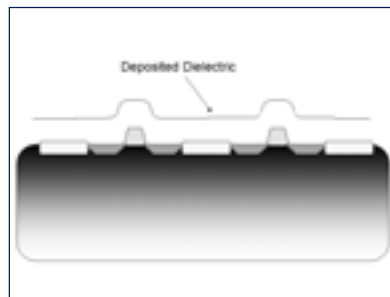

NNIN

CMF NanoCourses



CMP, page 3

CORNELL

How Else to Planarize?

- Several other techniques have been developed
 - Borophosphosilicate glass (BPSG) Reflow
 - Spin on Glass (SOG)
 - Resist Etchback

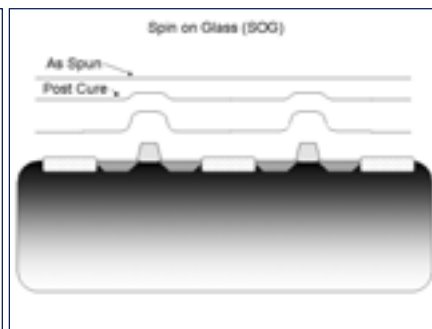
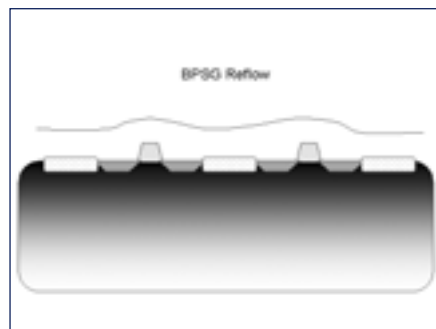

NNIN

CMF NanoCourses



CMP, page 4

CORNELL

Problems with Planarizing

- Other planarization techniques only partially remove step heights
- Local planarization instead of global planarization
- Limited ICs to 3-4 wiring levels

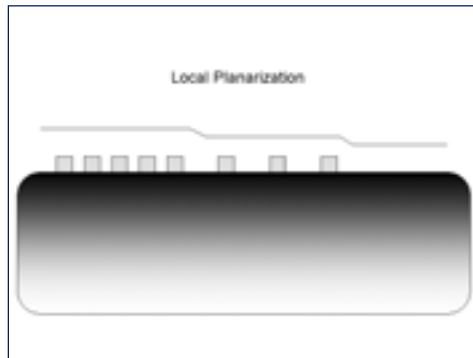

CMP – A New Approach

- Deposit film thicker than needed
- Polish film down until step heights are removed
- Process achieves global planarization... for the most part
- Allows for up to 9+ wiring levels in ICs

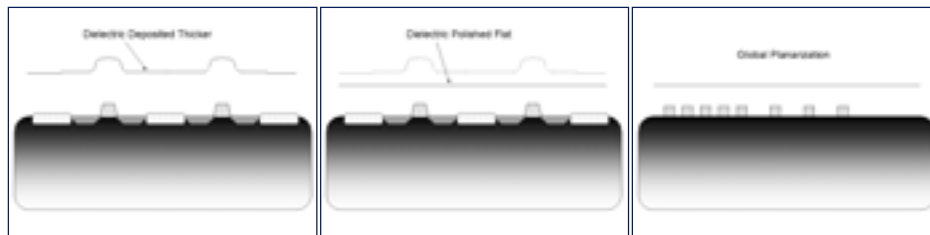

Strasbaugh 6EC – Lab Polisher

- Polishing table covered with polishing pad / slurry
- Carrier holds wafer against pad while turning
- Conditioning Arm – maintains removal rate
- Can process 3, 4, & 6 inch whole wafers only



NNIN

CMF NanoCourses



CMP, page 7

CORNELL

Damascene CMP - CMP's Other Trick

- Connects wiring levels in ICs
- Can be used for other materials as well

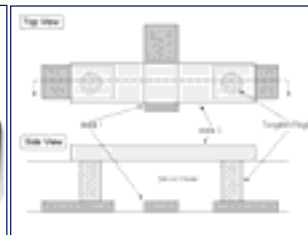
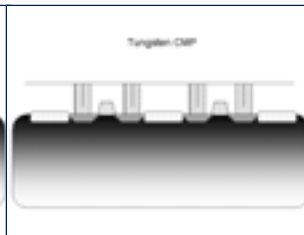
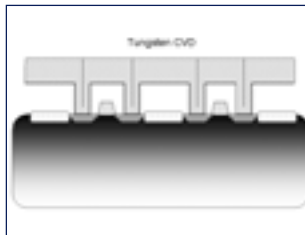
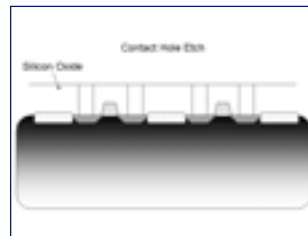

NNIN

CMF NanoCourses



CMP, page 8

CORNELL

Dual Damascene– An Even Fancier Trick

- Developed in the effort to make things cheaper / faster
- Utilized for all Cu wiring in advanced devices (i.e. Pentium 4, PowerPC)

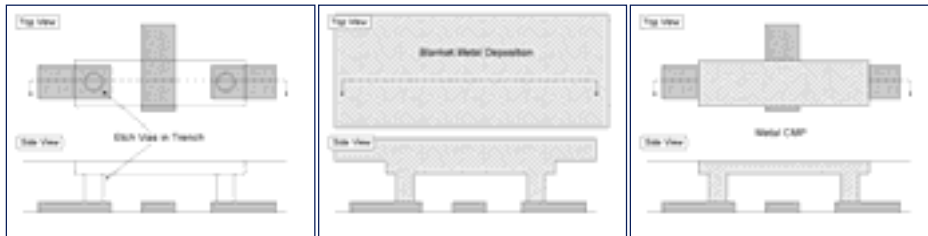
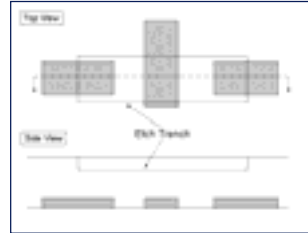

CMP Consumables

- Polishing Pads
 - Material designed for the purpose of the polishing
 - Hard for planarization / damascene polishing
 - Soft for reducing surface roughness
 - Needs to be compatible with the slurry being used
 - Hard pads need conditioning to maintain etch rates
- Slurries
 - Chemical / Mechanical action determined by slurry
 - Designed by slurry vendors for materials specific to IC industries
 - Oxide / Nitride
 - Polysilicon
 - Tungsten
 - Copper

CMP Processing Issues

- During planarization, removal rate is pattern dependant
- Damascene process has pattern issues as well
 - Erosion
 - Dishing
 - Pattern recess

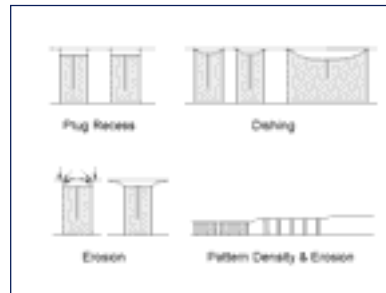
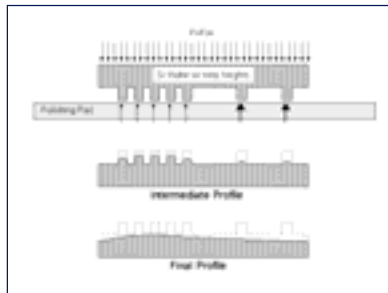

CMP Defects

- Scratches
 - Big scratches caused by large agglomerated slurry dumps, loose diamond, and other large particles – should be preventable
 - Small ‘micro’ scratches caused by smaller slurry agglomerations – must develop process to be insensitive to microscratches
- Slurry particles on wafer
 - Important to adequately clean wafer after polishing
 - PVA brushes used in modern equipment
 - Dilute ammonium hydroxide used to get zeta potential ‘on your side’
 - Dilute HF can be used to etch particles off wafer

CMP Overview

- **CMP opens up new possibilities in nanofabrication**
- **Now being used in many other industries**
 - Optoelectronics
 - MEMS
 - Hard disk drive heads
- **Unique among etch techniques in that it is spatially selective**
- **Is not designed to do everything**
- **Adds its own challenges to a process flow**



NanoCourses 2004, Section 3

Practical Thin Film Technology

The Flatland of Thin Films
Puttin' 'em on and Takin' 'em off

Bonding, Embossing and Soft Lithography Techniques by Mandy Esch

Presented by the
CNF Technical Staff
for the education of CNF Users,
Potential Users, and Industrial Sponsors



CNF NanoCourses



Bonding & Embossing, page 1



Bonding

**Bonding = Permanent or non-permanent
coupling of materials**

Methods:

- Anodic bonding
- Direct bonding
- Bonding with intermediate layers



CNF NanoCourses



Bonding & Embossing, page 2



Anodic Bonding - Substrates



Anodic Bonding

- Voltage: 500-1200 V
- Temperature: 350-500°C

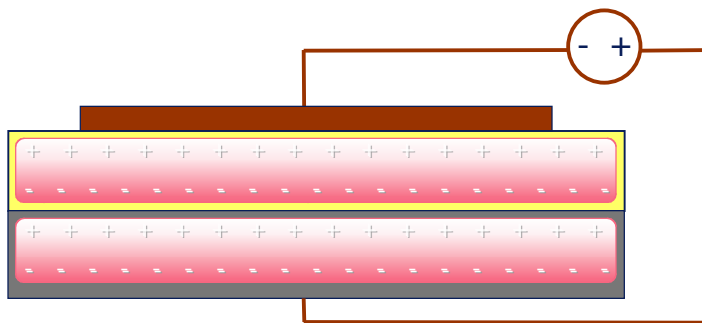

Anodic Bonding

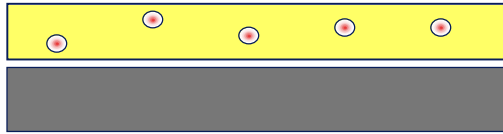

- Contain sodium ions
- Have a thermal expansion coefficient close to that of silicon

Anodic Bonding

- Bio-MEMs
- microfluidics
- pressure sensors
- solar cells
- piezoresistive applications
- packaging

But: Because of the presence of charged mobile ions and the high voltages necessary, this technique can not be used for semiconductor devices.

Silicon Fusion Bonding



Silicon Fusion Bonding

Pre-bonding

Annealing

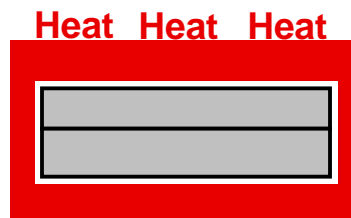
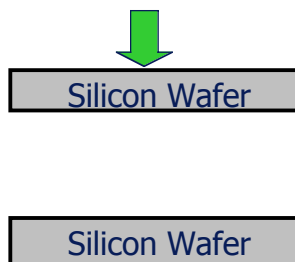

Inspection with transmission infrared microscopy, X-ray topography or ultrasonic methods

Surface Properties

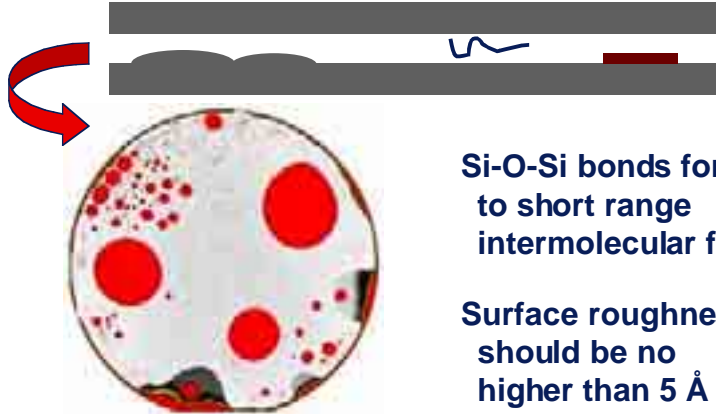

Si-O-Si bonds form due to short range intermolecular forces

Surface roughness should be no higher than 5 Å

Contamination or entrapped gases will diminish the quality of the bond!

picture source: <http://www.sonoscan.com/systems/C-SAM%20AW-2000.htm>

NNIN

GNF NanoCourses



Bonding & Embossing, page 9

CORNELL

Surface Preparation

RCA clean - SiOH groups

1) **RCA1:** NH_4OH (29%) : H_2O_2 (30%) : H_2O
1 : 1 : 5
for 5 min at 70°C

2) **RCA2:** HCl (37%) : H_2O_2 (30%) : H_2O
1 : 1 : 6
for 5 min at 70°C

3) **RCA1**

HF dip - SiH groups

NNIN

GNF NanoCourses



Bonding & Embossing, page 10

CORNELL

Intermediate Layer Bonding

- Used to bond materials that cannot be bonded with anodic or direct bonding:
for example gallium arsenide
- Non permanent bonding of a substrate to a handle wafer

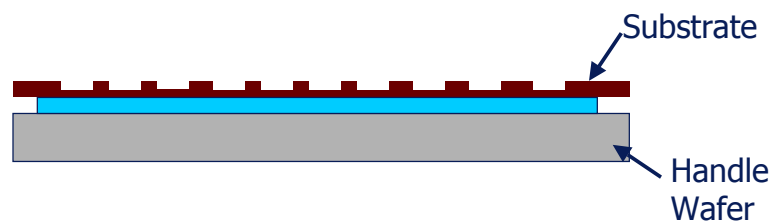

Intermediate Layer Bonding

- Metals (eutectic bonding)
- Glass (glass-frit bonding)
- Glues
- PECVD oxide
- Photoresist
- PMMA
- Acrylic
- Waxes

To bond the wafers **Force and Heat** are necessary.

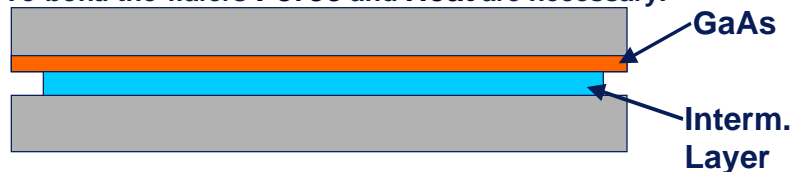

This type of bonding
can be non-permanent!

Hot Embossing

- Microstructuring of thermoplastic polymers (bulk material or thin film)
- High-precision molding of microfluidic components with a large aspect ratio and micro-optical components is possible

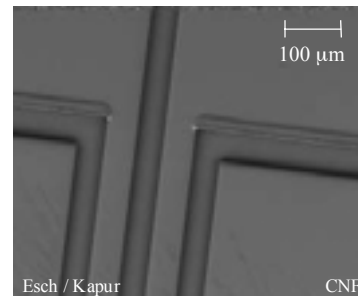
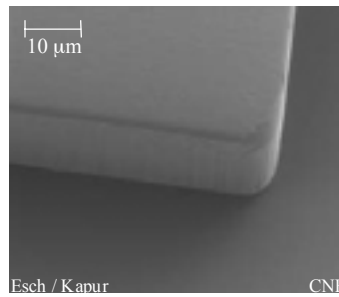

Hot Embossing

A) Microfluidics

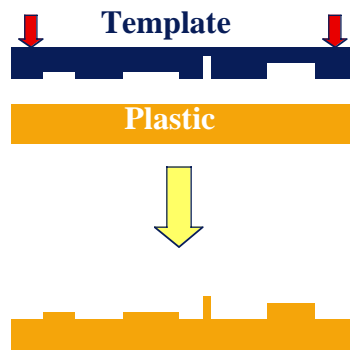

B) Nano-Imprint Lithography

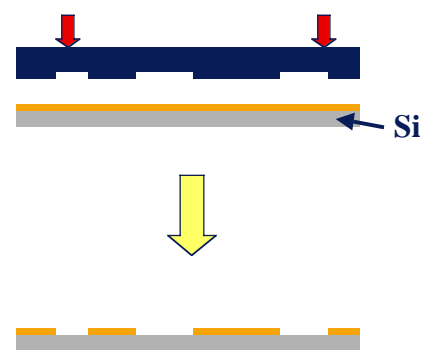

Several levels and back side alignment are possible.

Process

To avoid thermal stress between substrate and template, ΔT should be as small as possible.

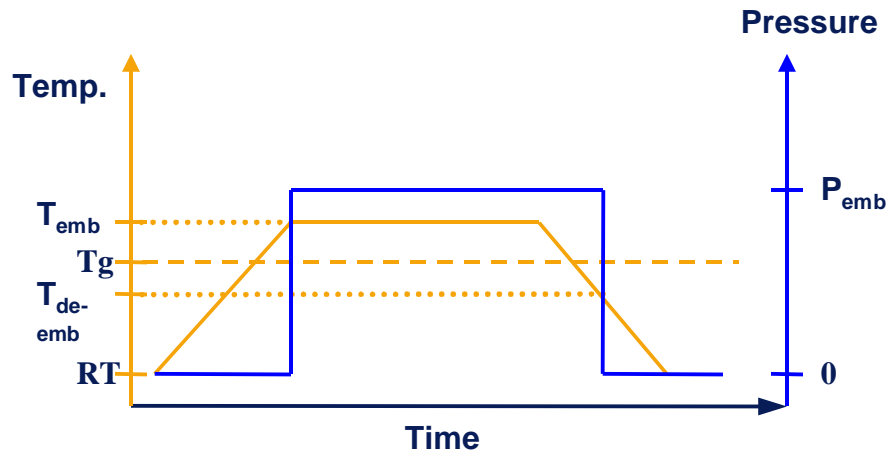

Materials for Embossing

- **Substrates**
 - Thermoplastic bulk polymers such as polycarbonate, PETG, Acrylic
 - Thin films such as PMMA, SU-8
- **Molds**
 - Silicon processing
 - CNC machining (limit 50 μm)
 - LIGA (Ni)
 - DEEMO

Advantages

- Low-cost substrate material
- Easy way of microstructuring
- A complex micromachining step is only necessary once
- Rapid prototyping and production possible

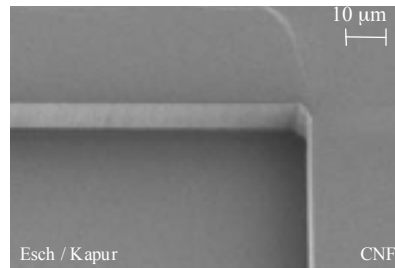

Stamp Geometries

- The stamp geometry defines the flow pattern the material undergoes.

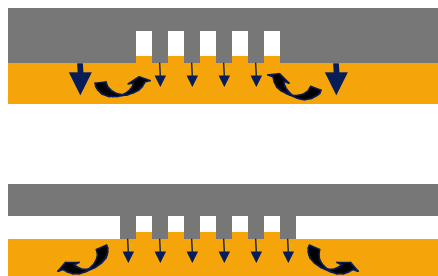

Stamp Geometries

- Narrow grooves are easier to fill than big squares
- Angled sidewalls facilitate better de-embossing
- Antiadhesive layers such as fluorinated Teflon-like polymer films or self assembled monolayers of organic molecules improve phenomena observed during de-molding.

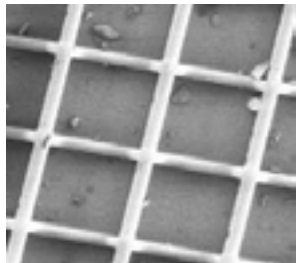

Microfluidic Channels

- Kameoka et al., Anal. Chem., 73, p. 1935

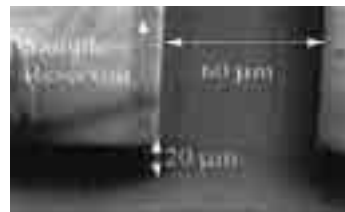
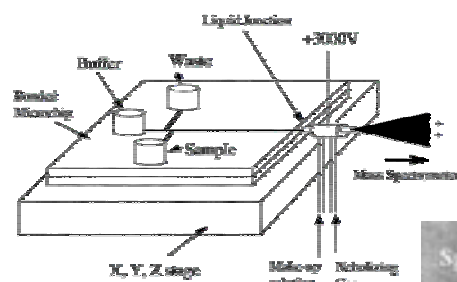

Example: Nano-Imprinting

- Stephen Chou et al., Science 272, p. 85

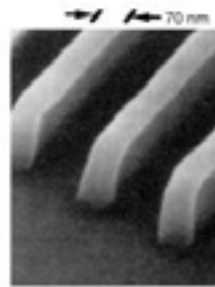
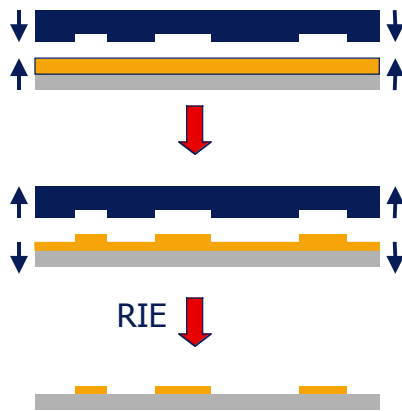

Fig. 4. SEM micrograph of a perspective view of strips formed by compression molding into a PMMA film. The strips, 70 nm wide and 200 nm tall, have a high aspect ratio, a surface roughness of <math><3\text{ nm}</math>, and nearly perfect

Soft Lithography

- Collective name for techniques based on self-assembly and molding
- Rapid inexpensive way of forming patterns
 - Micro-contact printing
 - Microfluidic printing
 - “Dip Pen”
 - Replica molding

For overview articles on soft lithography look for publications by G. M. Whitesides, Harvard University

Microcontact Printing

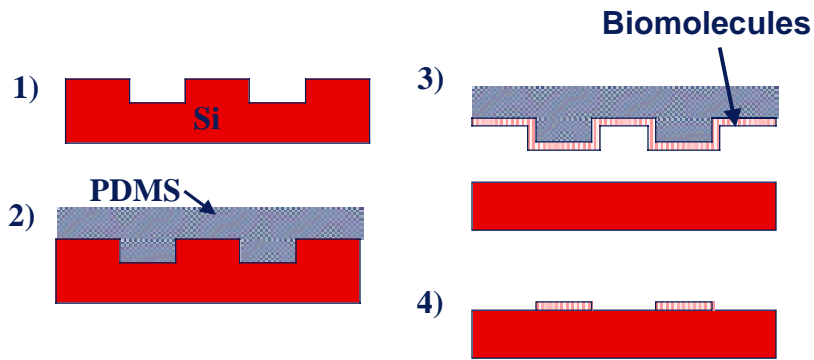

Microfluidic Printing

Silicon
template

PDMS was
cured on the
silicon

PDMS placed
on a glass
slide

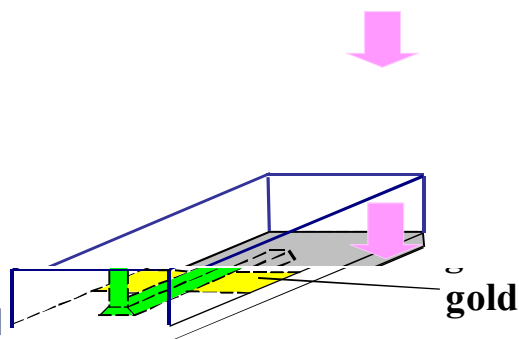

“Dip-Pen” Technology

- Piner et al., Science 283 (5402), 661

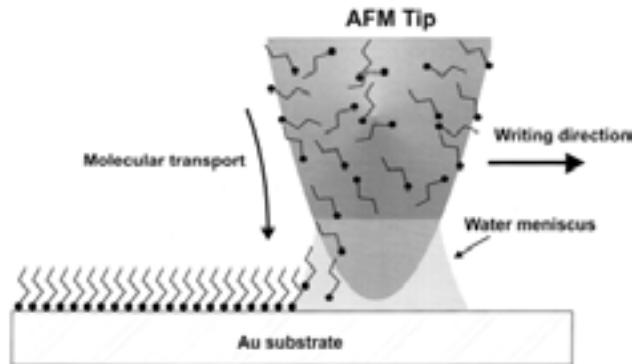

- 30 nm lines of alkanethiols

Replica Molding

- The elastomeric mold simplifies the separation between replica and mold

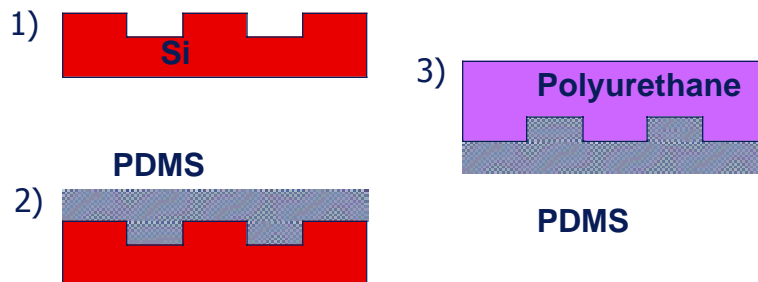

Applications of Soft Lithography

- **Biology and Biochemistry:**
 - 1) Biochemical Assays
 - 2) Capillary electrophoresis
 - 3) Patterned Cell Culture
- **Patterning of Semiconductor Materials**
 - 1) Patterning of non-planar (curved) surfaces
 - 2) Transistor fabrication
 - 3) Selective deposition (CVD) of thin films
 - 4) Patterning with organic molecules (SAMs)

Immobilization of Nucleic Acids

- Steel et al., *Biophysical Journal*, 79, 975-981

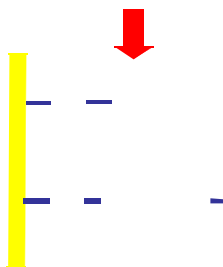

But: DNA will stick to gold surfaces ---
Block them with mercaptohexane!

Pattern of Biomolecules

- Nucleic Acids
 - Antibodies
 - Organic Monolayers
 - Enzymes
- Covalent attachment
 - Adsorption
 - Encapsulation in gels
- Functionality
 - Accessibility

NanoCourses 2004, Part 3

Practical Thin Film Technology

The Flatland of Thin Films
Puttin' 'em on and Takin' 'em off

Wet Etch Processes
by
Phil Infante

Presented by the
CNF Technical Staff
for the education of CNF Users,
Potential Users, and Industrial Sponsors



CNF NanoCourses



Wet Etch Processes, page 1



Wet Processes

- Many of the etching processes for thin film removal and pattern transfer involve liquid chemicals
- 20-25 years ago, etching processes for microelectronics were almost exclusively performed by wet chemistry
- The need for high resolution pattern transfer spurred the development of "dry etching" processes
- Today, plasma based etching is the norm in the microelectronics industry
- However wet etching is still an integral part of micro-fabrication as it provides certain advantages over plasma processes



CNF NanoCourses



Wet Etch Processes, page 2



Disadvantages

- The major disadvantage of wet etching is poor resolution
- Wet etch processes are typically "isotropic," i.e., the lateral etch rate is the same as the vertical etch rate
- For "large" features this may be acceptable

Wet Etching

Before etch:

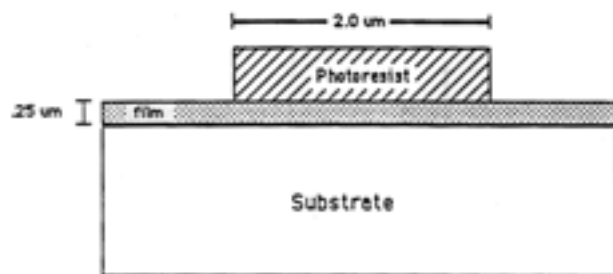

After etch:

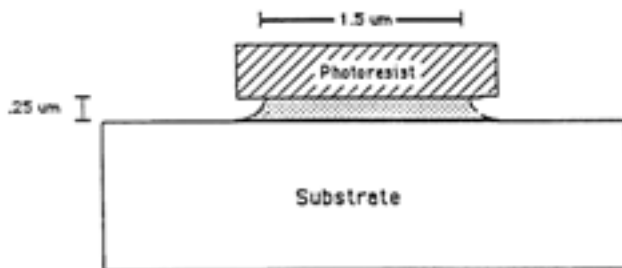

Linewidth

- However, if the linewidth is on the order of the film thickness, problems can occur

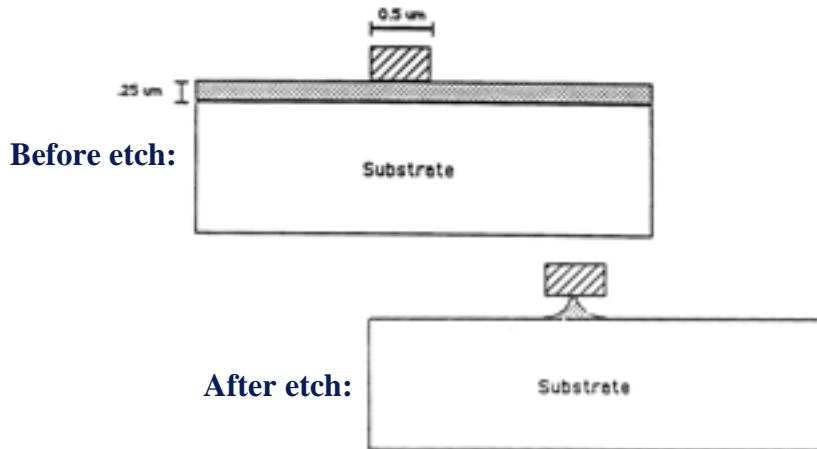

Advantages of Wet Etching:

- 1) Inexpensive:
 - Chemicals cost on the order of \$8 per gallon
 - An etch sink and HEPA costs \$20,000
 - Plasma type etchers cost on the order of 0.1 to 0.3 million dollars and have higher operating costs
- 2) Batch processing results in high throughput
- 3) Etch rates are determined by chemistry alone
 - Etch rates for films are thus constant, provided the phase variables (temperature and concentration) are controlled
 - This results in very uniform etching (with proper agitation)
- 4) Because etch rates depend on chemistry alone, very high selectivities are possible
 - This is perhaps the most attractive feature of wet etching
 - 6:1 buffered HF etches SiO_2 at 110 nm/min
 - Silicon is not etched
 - Phosphoric acid at 160°C etches Si_3N_4 at 10 nm/min
 - SiO_2 etches at $< 5 \text{ \AA}/\text{minute}$

Release Application



Etching of Silicon with Potassium Hydroxide

- KOH etches the $\langle 100 \rangle$ and $\langle 110 \rangle$ crystal planes faster than the $\langle 111 \rangle$ planes with a high degree of selectivity
- Generally the selectivity of $\langle 100 \rangle : \langle 110 \rangle : \langle 111 \rangle$ is about 300:600:1
- The KOH silicon etch has a high selectivity to SiO_2 and a near infinite selectivity to LPCVD Si_3N_4
- Typical KOH concentrations are around 30-40 % by weight
 - This gives 100 etch rates at about 1-2 $\mu\text{m}/\text{min}$
- Lowering the concentration gives slightly better etch rates but with decreased selectivity
 - Higher concentrations give the best selectivity between plane orientations

Silicon Crystal Lattice

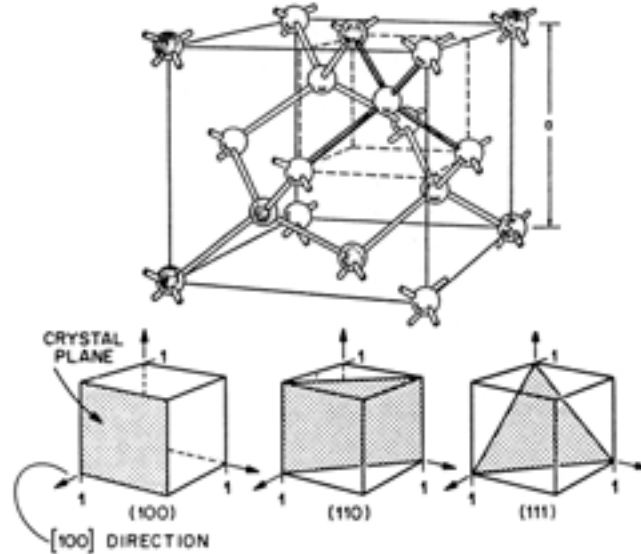

NNIN

CNF NanoCourses



Wet Etch Processes, page 9

CORNELL

<100> Si Wafer

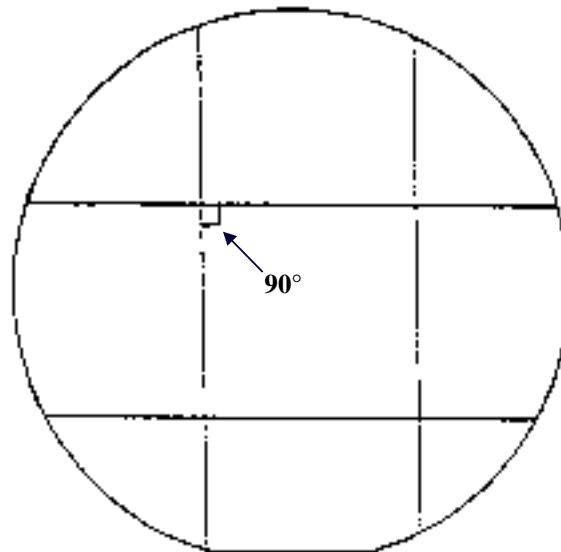

NNIN

CNF NanoCourses



Wet Etch Processes, page 10

CORNELL

<100> Si Wafer, Continued

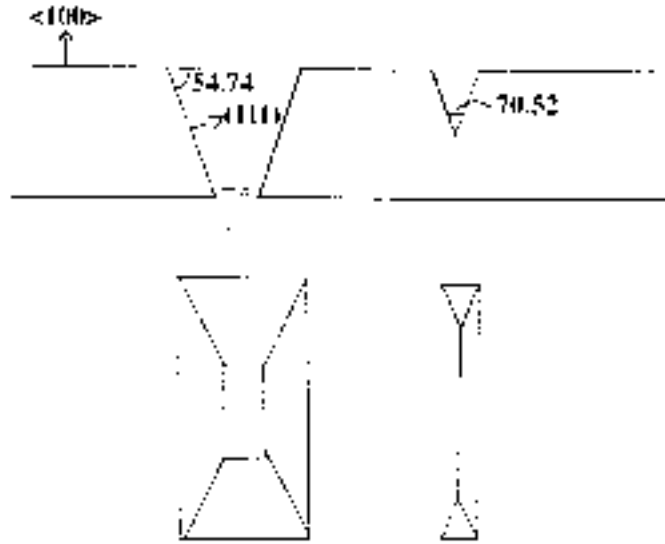

NNIN

CNF NanoCourses



Wet Etch Processes, page 11

CORNELL

<100> Si Wafer, Continued

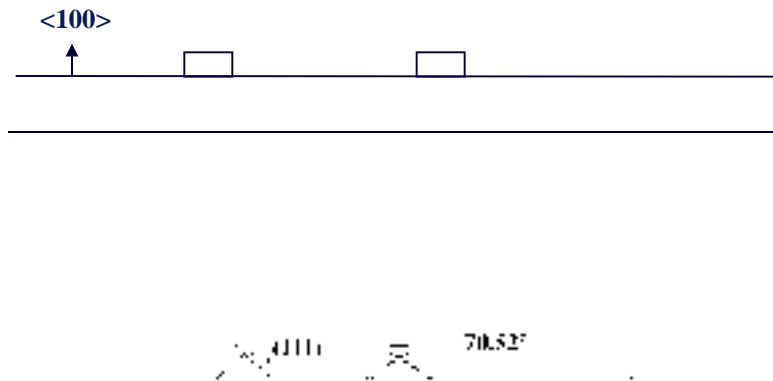

NNIN

CNF NanoCourses



Wet Etch Processes, page 12

CORNELL

<110> Si Wafer

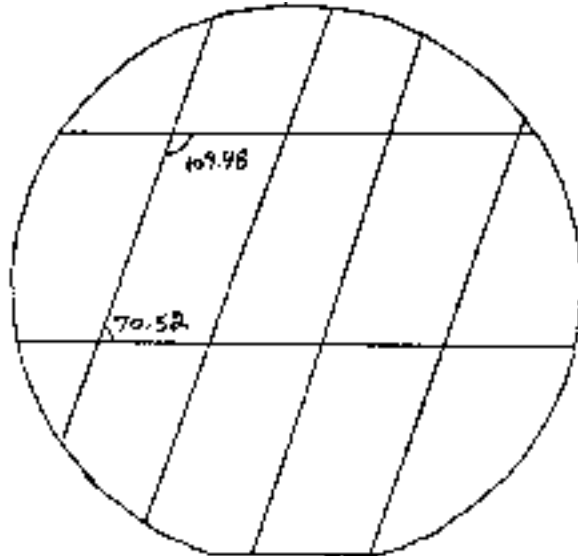

NNIN

CNF NanoCourses



Wet Etch Processes, page 13

CORNELL

<110> Si Wafer, Continued

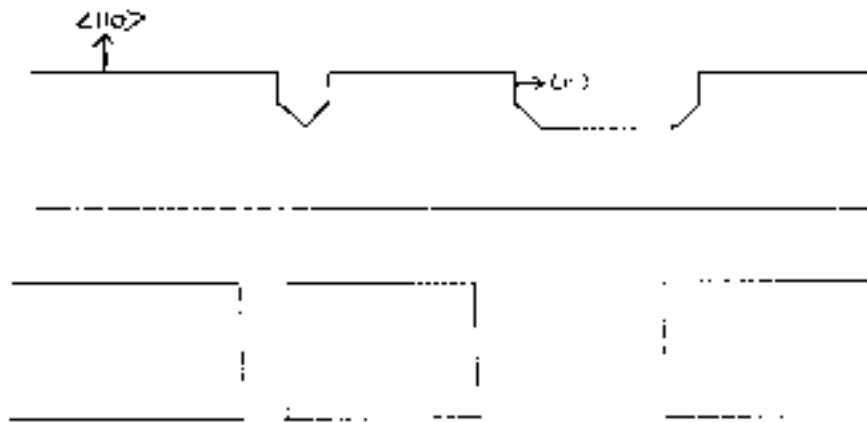

NNIN

CNF NanoCourses



Wet Etch Processes, page 14

CORNELL

Common Chemical Concentrations

Acids		wt%
Acetic acid	CH ₃ CO ₂ H	99.7 (minimum)
Hydrochloric acid	HCl	36.5-38.0
Nitric acid	HNO ₃	69.0-71.0
Perchloric acid	HClO ₄	69.0-72.0
Phosphoric acid	H ₃ PO ₄	85.0 (minimum)
Sulfuric acid	H ₂ SO ₄	95.0-98.0
Alkalis		wt%
Ammonium hydroxide	NH ₄ OH	28.0-30.0 (as NH ₃)
Hydrazine monohydrate	NH ₂ NH ₂ H ₂ O	99.0 (minimum)
Potassium hydroxide	KOH	85.0 (minimum)
Sodium hydroxide	NaOH	90.0 (minimum)
Other Chemicals		wt%
Ammonium fluoride sol.	NH ₄ F	40-41
Hydrogen peroxide sol.	H ₂ O ₂	30.0-32.0
Methanol	CH ₃ OH	99.8
2-Propanol	(CH ₃) ₂ CHOH	99.5 (typical)
Sodium peroxide	Na ₂ O ₂	96.0 (minimum)
Mixtures*		Vol
Aqua regia	HNO ₃ -HCl	1:3
Buffered HF (BHF)	HF-NH ₄ F	1:x (typically 1:6)
P-etch	HNO ₃ -HF-H ₂ O	1:3:60

* All mixtures in this chapter are by volume unless stated otherwise.



CNF NanoCourses



Wet Etch Processes, page 15



Common Wet Etch Processes

- **Silicon Dioxide:**
 - **6:1 ammonium fluoride: 48% hydrofluoric acid**
 - Common name 6:1 Buffered Oxide Etch
 - Note: 48% HF is commonly called "Straight HF"
 - Etch rate -110 nm/min for thermal SiO₂: Faster for CVD oxide
 - Selectivity to silicon: Infinite
 - Selectivity to Si₃N₄: 100:1
 - Does not lift photoresist: If oxide stripping is to be done, i.e. no resist pattern, use straight HF and deionized water
 - 10:1 HF:H₂O etches thermal oxide at 36 nm/min

Note: All etch rates at 25°C except where noted
ALL RATES ARE APPROXIMATE!!



CNF NanoCourses



Wet Etch Processes, page 16



Wet Etch Processes, Continued

- **Aluminum:**
 - 4: Phosphoric acid
 - 4: Glacial acetic acid
 - 1: Nitric acid
 - 1: Deionized water
 - Etch Rate: 40 nm/min
 - Selectivity to Si and SiO₂: Infinite
- **Polysilicon:**
 - 150: Nitric acid
 - 75: Deionized water
 - 1: 48 % HF
 - Etch Rate: 200 nm / min
 - Selectivity to SiO₂ -10:1
 - Note: Evolves heat when mixed



Wet Etch Processes, Continued

- **Silicon Nitride.**
 - Phosphoric Acid @ 160°C
 - Etch rate: 10 nm/min
 - Selectivity to SiO₂ and Si: > 20:1
- **SEE:**
 - Ghandi, "Microfabrication" or Vossen and Kern, "Thin Film Processes" for extensive tables of wet etch solutions and properties



Safety

- **The strong acids and bases pose a serious contact hazard**
 - Proper handling and protective gear are essential
 - Nitrile rubber gloves and a face shield are mandatory
 - A vinyl apron is recommended



Disposal

- **Wet chemical waste must be disposed of properly**
 - Cornell does not perform “in house” neutralization
 - Waste bottles for each chemical mixture should be created
 - Do not have “common” Acid or Base waste containers



High Temperature Processing



CNF NanoCourses



Wet Etch Processes, page 21



Outline

- Annealing
- Thermal Oxidation of Silicon
- Thermally Activated Chemical Vapor Deposition (CVD)
- Plasma-Enhanced Chemical Vapor Deposition (PECVD)



CNF NanoCourses



Wet Etch Processes, page 22



Annealing

- Heat sample between 400 and 1200°C
- Expose sample to inert or reducing ambient

Reasons for Annealing

- Changes microstructure of substrates or films
- Changes conductivity, stress, etch resistance, etc
- Can cause two materials to react

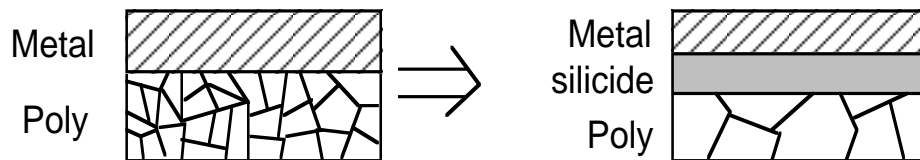

Thermal Oxidation of Silicon

- Heat Si to high temperature $> 700^{\circ}\text{C}$
- Expose Si to oxidizing ambient O_2 or H_2O
- Si reacts with oxidant to form SiO_2

Mechanism

- Oxidant diffuses through oxide to Si-SiO₂ interface to react with Si

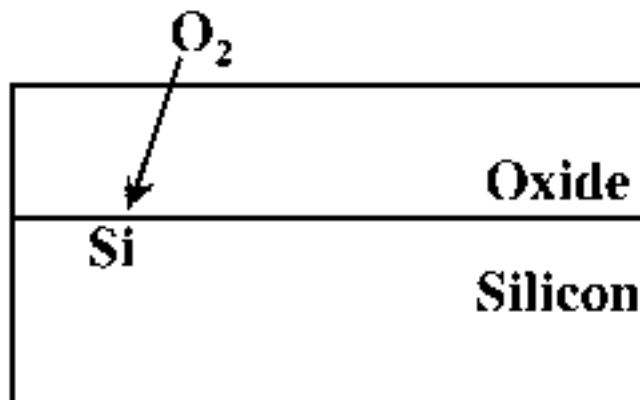

Growth of Oxide

- From the densities and molecular weights of silicon and silicon dioxide we can calculate that:
 - For a growth of oxide of thickness = d , a layer of silicon = $0.44 d$ is consumed
- The oxide grows *down as well as up!*
 - (This can sometimes be quite a problem)

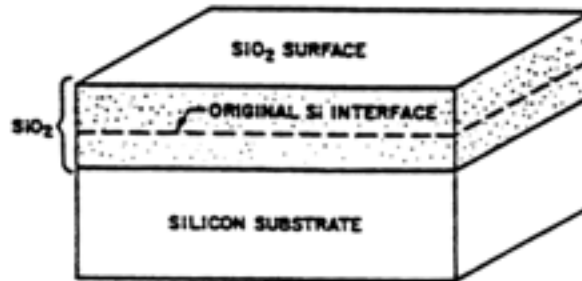

Oxidation Rates

- Two rate limiting processes:
 - *Chemical reaction* at oxide-Si interface
 - *Diffusion* of oxidant through the oxide layer on the surface to the oxide-Si interface
- The slower of these two processes determines the oxidation rate

Chemical Reaction Limited Oxidation

- Rate is determined by chemical kinetics
- Characterized by a linear rate constant
 - Oxide thickness = $C_1 \times$ (oxidation time)
- Linear rate relationship holds for oxidation on bare silicon or silicon with a thin surface oxide



Diffusion Limited Oxidation

- Rate is controlled by oxidant diffusion through existing oxide
- Characterized by parabolic rate constant
 - (oxidation time) $\times C_2 =$ (oxide thickness)²
- Parabolic rate relationship holds for oxidation on silicon with a *substantial* thickness of surface oxide



Factors Affecting Oxidation Rates for Thin Oxides

- **Surface orientation**
 - Atomic density
 - Number of available Si bonds
 - Steric hinderance (bond stress)

- --> Orientation of surface affects surface kinetics and hence *linear rate constant*

- **Impurities in silicon**
 - Affect linear rate constant



Factors Affecting Oxidation Rates for Thick Oxides

- **Oxidizing ambient**

- **Oxidant pressure**
 - Diffusion of oxidant proportional to partial pressure of oxidant

- **Impurities in oxide**
 - Affect parabolic rate constant



Pressure and Orientation

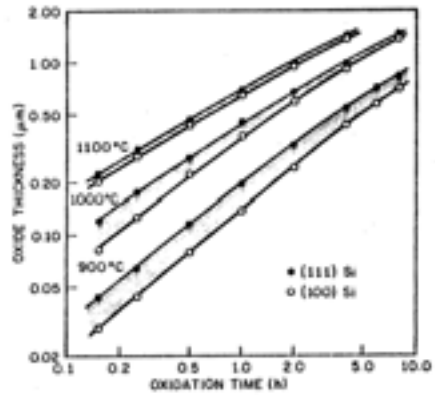
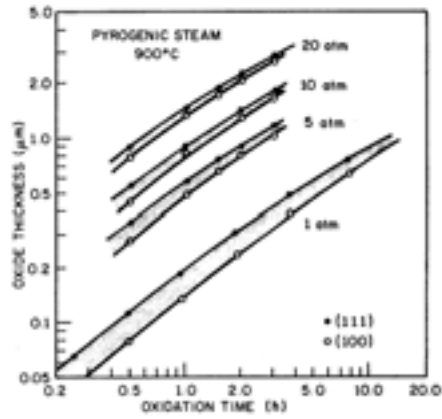

Boron Doping

THERMAL OXIDATION OF SINGLE CRYSTAL SILICON

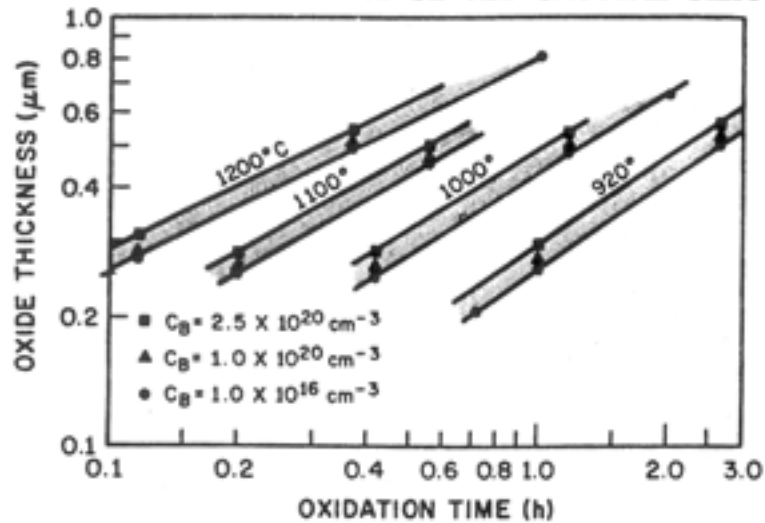

Boron Doping

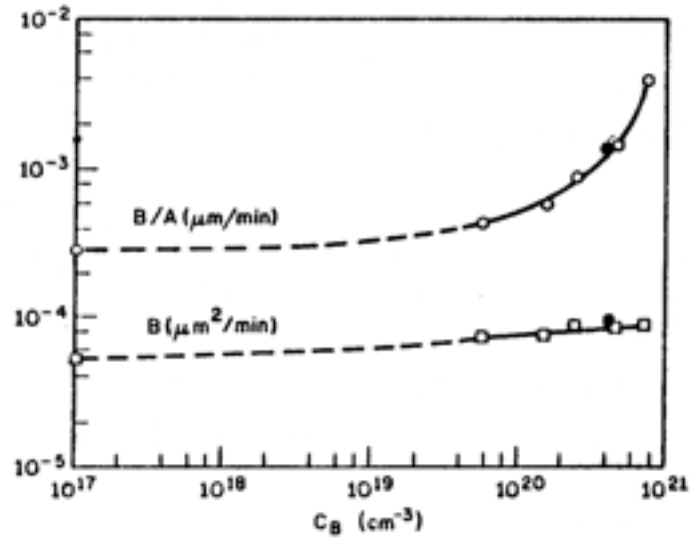

Typical Oxidation System

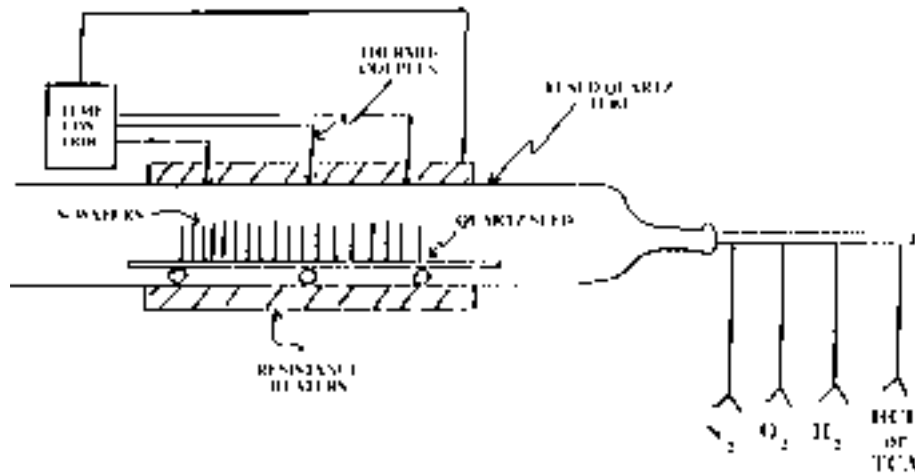

Dry Oxidation

- Oxidize in O_2
- Anneal in N_2 or Ar to stabilize charges at oxide-Si interface
- Oxidation rate is slow - better process control for thin oxides
- **PRACTICAL THICKNESS RANGE:**
 - 80 Å to 1500 Å

NNIN

CNF NanoCourses



Wet Etch Processes, page 37

CORNELL

Wet Oxidation

- Oxidant is a mixture of H_2 and O_2 (steam)
- Fast oxidation rate (large A, B/A)
- **PRACTICAL THICKNESS RANGE:**
 - 500 Å to 1.2 μm
- Requires special gas injector

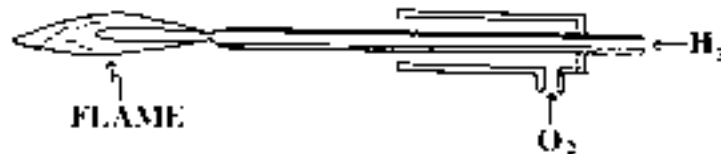

NNIN

CNF NanoCourses



Wet Etch Processes, page 38

CORNELL

Thermal Oxide Characteristics

- **Excellent insulator**
 - Picoamp leakage current
- **10 Megavolt/cm dielectric strength**
 - (1000 Å oxide breaks down at 100 V)
- **Thermal SiO₂ is non-contaminating to most other materials used in microfabrication**



CNF NanoCourses



Wet Etch Processes, page 39



Types of Cleaning Processes

- **Pre-oxidation clean:**
 - Since oxidation temperatures are high, contaminants will diffuse into the MOS structure
 - Concentrations of some contaminants as low as $3E10$ atoms/cm² can cause shifts in electrical characteristics and impair reliability
 - A cleaning process is required to remove organic and metallic contaminants prior to oxidation
- **Two popular cleans:**
 - 1) RCA clean
 - NH₄OH+H₂O₂+H₂O
 - HCL+H₂O₂+H₂O
 - 1) H₂SO+ H₂O₂ (liquid piranha)



CNF NanoCourses



Wet Etch Processes, page 40



Furnace Chlorine Sources

- Remove alkalis and metals from furnace chambers
- HCl Gas
 - The classic Cl source
 - Can corrode plumbing, adding more contamination than it removes
- 1,1,1 trichloroethane (TCA)
 - Liquid source
 - Bubble a carrier gas (nitrogen) through liquid
 - Reacts inside tube to form HCl and CO₂
 - Chance of corrosion greatly reduced



CNF NanoCourses



Wet Etch Processes, page 41



Oxidation Capabilities at CNF

- Wet and dry thermal oxidation
- TCA or HCl chlorine source
- 100 Å to 1.2 μm thickness
- Restrictions:
 - Whole 3-6 inch wafers preferred
 - Must be device quality silicon
 - No metallizations prior to oxidation
 - Polymers must be removed *prior* to pre-furnace clean
 - Implanted areas must be capped with oxide







CNF NanoCourses



Wet Etch Processes, page 42



Chemical Vapor Deposition (CVD)









Chemical Vapor Deposition

- Substrates are placed in a reactive ambient at a temperature and pressure designed to induce a controlled deposition of a film on a substrate

Common CVD Reactions:

<u>PR</u>	<u>REACTANTS</u>	<u>METHOD</u>	<u>TEMP (°C)</u>	<u>COMMENTS</u>
Polysilicon	SiH ₄	LPCVD	580-650	May be <i>in situ</i> doped
Silicon Nitride	SiH ₄ + NH ₃	LPCVD	700-900	
	SiCl ₂ H ₂ + NH ₃	LPCVD	650-750	
	SiH ₄ + NH ₃	PECVD	200-350	
	SiH ₄ + N ₂	PECVD	200-350	
SiO ₂	SiH ₄ + O ₂	APCVD	300-500	Poor step coverage
	SiH ₄ + O ₂	PECVD	200-350	Good step coverage
	SiH ₄ + N ₂ O	PECVD	200-350	
	Si(OC ₂ H ₅) ₄ [TEOS]	LPCVD	650-750	Liquid source, conformal
	SiCl ₂ H ₂ + N ₂ O	LPCVD	850-900	Conformal
Doped SiO ₂	SiH ₄ + O ₂ + PH ₃	APCVD	300-500	PSG
	SiH ₄ + O ₂ + PH ₃	PECVD	300-500	PSG
	SiH ₄ + O ₂ + PH ₃ + B ₂ H ₆	APCVD	300-500	BPSG, low temperature flow
	SiH ₄ + O ₂ + PH ₃ + B ₂ H ₆	PECVD	300-500	BPSG, low temperature flow

Basic Mechanisms of CVD

- 1) Transport of reactant to surface
- 2) Adsorption of reactant at surface
- 3) Reaction at surface
- 4) Desorption of product from surface
- 5) Transport of product away from surface

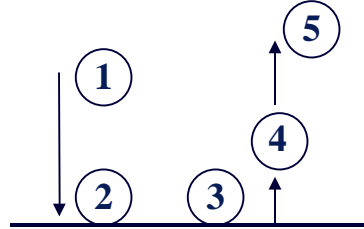

- Energy to drive the reaction can be supplied by a variety of sources (thermal, electrons, photons)
- The SLOWEST event will determine the deposition rate



CNF NanoCourses



Wet Etch Processes, page 45



Reactions

- In reality, chemical reactions may not only take place at the surface but in the gas phase as well
- Heterogeneous Reactions
 - Occur at or near the substrate surface
 - Are much more desirable
 - Generally produce higher quality films
- Homogeneous Reactions
 - Reactions occur in the gas phase
 - Generate clusters of depositing material
 - Result in poor adhering and low density films
 - Produce films with higher defects
- Heterogeneous reactions are favored over homogeneous reactions



CNF NanoCourses



Wet Etch Processes, page 46



Transport of Reactants to the Surface

- Mean Free Path

$$\lambda = kT/\sqrt{2}\pi P\sigma^2$$

- P = Pressure
- σ = Diameter of molecule
- k = Boltzman constant

- Diffusion to Surface

- Boundary Layer:
 - A gas velocity transition region between the solid surface of the sample or chamber ($v = 0$) and the free gas stream ($v = x$)

$$\delta = 2L/3\sqrt{Re}$$

- d = Boundary layer
- L = Length of region
- Re = Reynolds number



CNF NanoCourses



Wet Etch Processes, page 47



Reynolds Number

- Reynolds number:

- A dimensionless number used to represent the ratio inertial effects to viscous effects in fluid motion

$$Re = \rho vL/\mu$$

- v = gas velocity
- μ = viscosity
- ρ = fluid density
- L = length from edge

- Reynolds number is proportional to gas velocity and the boundary layer is inversely proportional to $Re^{1/2}$

- Faster gas velocity = smaller boundary layer



CNF NanoCourses



Wet Etch Processes, page 48



Reynolds Number, Continued

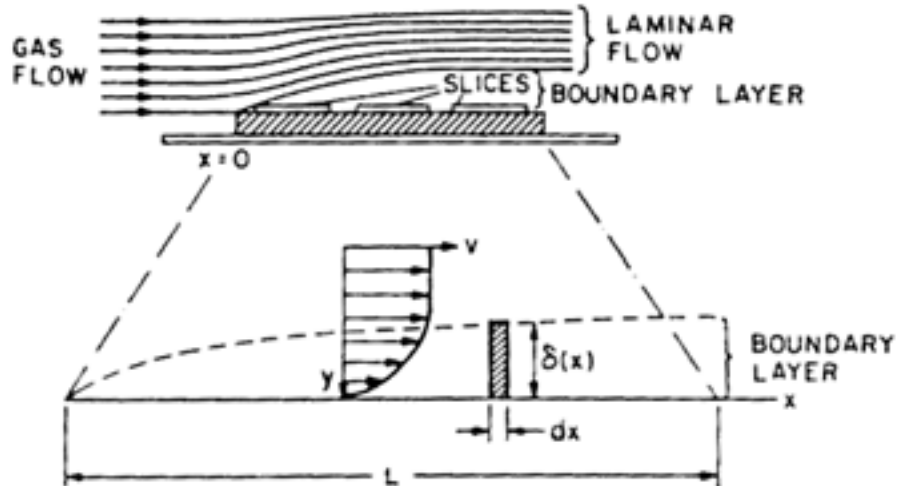

Transport of Reactants

- Transport of Reactants to the Surface Depends on:
 - Reactant concentration in the gas stream
 - Deposition temperature
 - Pressure
 - Boundary layer thickness
- We want to optimize process parameters to get the gas to the surface to react rather than react in the gas stream

Adsorption

- Depends on substrate binding energy
- Depends on reactant vapor pressure
 - Vapor pressure ~ exp [Temp]
- Non-zero probability that a reactant will leave surface before it can react
- Depends on gas species used for deposition



Surface Reaction

- Surface reactions can be modeled by a thermally activated process:
$$R = R_0 \exp [E_a/kT]$$
- The surface reaction increases with increasing temperature
- At high temperatures, the reaction rate will proceed faster that the gases can reach the sample
 - This is a *mass transport limited* process
- At low temperatures, the reaction rate is slower than the gas supply rate
 - This is a *reaction rate limited* process



Growth Rate for CVD Films

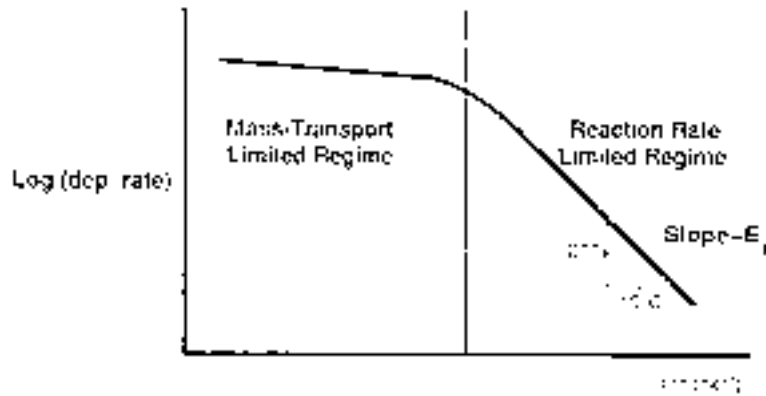

- Reaction rate limited processes require precise temperature control and are more tolerant to gas transport fluctuations
- Mass transport limited processes require precise control of reactant concentration at the surface and less control over the process temperature

Step Coverage

- Mass transport limited case:
 - The thickness at any point is dependent on the supply of reactants to the site
 - Reactant surface diffusion path length (L_s) is a strong function of temperature and mean free path length (λ) is a f_n of pressure

$\lambda, L_s \gg$ step geometry

$\lambda \gg$ step, $L_s \ll$ step

$\lambda, L_s \ll$ step



Reaction Limited Case:

- Lower temperature pushed process to be reaction rate limited without adversely effecting gas transport
- Transport of reactants to surface is efficient -- good conformality/uniformity
- Some gas chemistries may be transport limited even at lower temperatures



CNF NanoCourses



Wet Etch Processes, page 55



Types of CVD Processes

- Atmospheric CVD (APCVD)
- Low pressure CVD (LPCVD)
- Plasma-enhanced CVD (PECVD)



CNF NanoCourses



Wet Etch Processes, page 56



APCVD

- Typical reactor:
 - Pressure = 760 torr

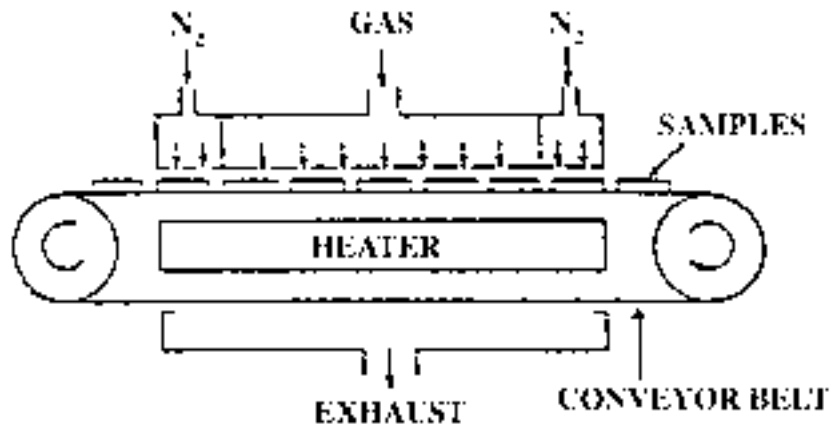

NNIN

CNF NanoCourses



Wet Etch Processes, page 57

CORNELL

APCVD, Continued

- Film Uniformity
 - Reaction constant is on the order of mass transfer coefficient
 - Transport effects are significant
 - Fair to poor uniformity
- Step Coverage
 - Mean free path on the order of step height
 - Poor transport over features
 - Poor step coverage

NNIN

CNF NanoCourses



Wet Etch Processes, page 58

CORNELL

LPCVD

- Typical reactor:
 - Pressure range 0.1 to 3 torr

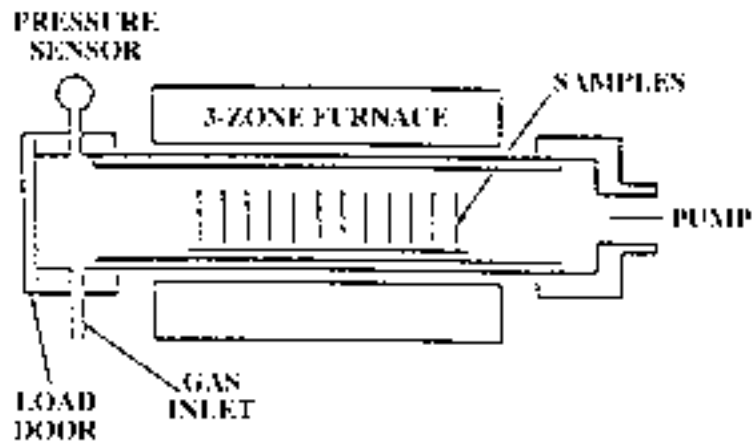

NNIN

CNF NanoCourses



Wet Etch Processes, page 59

CORNELL

LPCVD, Continued

- Film Uniformity
 - Deposition rate is reaction limited
 - Mass transfer is a strong inverse function of pressure
 - Chemical reaction constant is a weak function of pressure
 - Efficient transport and surface reaction limited means good uniformity
- Step Coverage
 - Mean free path large compared to step geometry
 - Good step coverage

NNIN

CNF NanoCourses



Wet Etch Processes, page 60

CORNELL

Problems with LPCVD

- Small gas volume results in gas depletion or loading effect
- Process optimization can be difficult, especially for production volumes
- Film deposits on chamber walls, can cause particulate problems

PECVD

- Typical reactor:
 - Pressure range
0.1 torr to 0.6 torr
 - Temperature range
100°C to 400°C

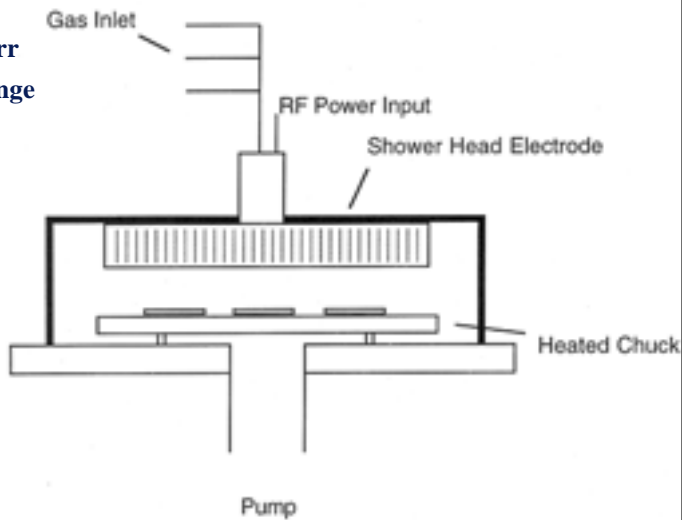

Advantages & Disadvantages

- **Advantages:**
 - RF plasma excites reaction
 - Temperature can be very low
 - Can deposit films on structures that cannot see high temperatures
 - Metals, GaAs, polyimide...
 - Energetic radicals tend to have high sticking coefficients and migrate well along surfaces after adsorption
 - Good uniformity/conformality
 - Higher deposition rates than LPCVD
- **Disadvantages:**
 - Films are not stoichiometric
 - By-products incorporated into the films
 - Gas phase reactions generate particulates



CNF NanoCourses



Wet Etch Processes, page 63



CVD Processes at CNF

- **LPCVD Silicon Nitride**
 - 800°C
 - $\text{SiH}_2\text{Cl}_2 + \text{NH}_3$
- **LPCVD Silicon Oxynitride**
 - 850°C
 - $\text{SiH}_2\text{Cl}_2 + \text{NH}_3 + \text{N}_2\text{O}$ or O_2
- **LPCVD Polysilicon**
 - 620-650°C
 - SiH_4 + optional PH_3 or B_2H_6
- **LPCVD SiO_2**
 - 420°C
 - $\text{SiH}_4 + \text{O}_2$
- **LPCVD SiO_2**
 - 850°C
 - $\text{SiH}_2\text{Cl}_2 + \text{N}_2\text{O}$



CNF NanoCourses



Wet Etch Processes, page 64



PECVD 25-400°C

- Silicon Nitride
 - $\text{SiH}_4 + \text{NH}_3$
- Silicon Oxide
 - $\text{SiH}_4 + \text{N}_2\text{O}$
- a-silicon
 - $\text{SiH}_4 + \text{Ar}$
- a-carbon
 - CH_4
- SiC
 - $\text{SiH}_4 + \text{CH}_4$



CNF NanoCourses



Wet Etch Processes, page 65



CVD Safety

- The major hazard of CVD applications is the gases used:

Properties of Common Gases used in CVD	
GAS	PROPERTIES
Silane	Toxic, flammable, pyrophoric
Dichlorosilane	Toxic, flammable, corrosive
Phosphine	Very toxic, flammable
Diborane	Very toxic, flammable
Arsine	Very toxic, flammable
Hydrogen chloride	Toxic, corrosive
Ammonia	Toxic, corrosive
Hydrogen	Nontoxic, flammable
Oxygen	Nontoxic, supports combustion
Nitrous Oxide	Nontoxic, nonflammable
Nitrogen	Usually inert
Argon	Inert



CNF NanoCourses



Wet Etch Processes, page 66

